

## SIMATIC HMI

### OP3 Operator Panel

#### Equipment Manual

#### Preface, Contents

---

		<b>1</b>
<b>Part I</b>	Introduction	∇
		<b>2</b>
<b>Part II</b>	Functions of the OP3	∇
		<b>12</b>
<b>Part III</b>	Installation and Commissioning	∇
		<b>14</b>
<b>Part IV</b>	Device Description, Test and Monitoring Functions	∇
		<b>15</b>
		<b>16</b>
<b>Part V</b>	Appendices	∇
		<b>A</b>
		<b>E</b>

---

#### Glossary, Index

6AV3591-1AD00-1AB0

Release 11/99

## Safety Guidelines

This manual contains notices which you should observe to ensure your own personal safety, as well as to protect the product and connected equipment. These notices are highlighted in the manual by a warning triangle and are marked as follows according to the level of danger:



### Warning

indicates that death, severe personal injury or substantial property damage **can** result if proper precautions are not taken.



### Caution

indicates that minor personal injury or property damage can result if proper precautions are not taken.

### Note

draws your attention to particularly important information on the product, handling the product, or to a particular part of the documentation.

## Qualified Personnel

Equipment may be commissioned and operated only by **qualified personnel**. Qualified personnel within the meaning of the safety notices in this manual are persons who are authorized to commission, ground and identify equipment, systems and circuits in accordance with safety engineering standards.

## Correct Usage

Note the following:



### Warning

The equipment may be used only for the applications stipulated in the catalog and in the technical description and only in conjunction with other equipment and components recommended or approved by Siemens.

Startup must not take place until it is established that the machine, which is to accommodate this component, is in conformity with the guideline 89/392/EEC.

Faultless and safe operation of the product presupposes proper transportation, proper storage, erection and installation as well as careful operation and maintenance.

## Approvals

The approvals that apply to the device are detailed in the Chapter *Technical Data*.

## Trademarks

The registered trademarks of Siemens AG are listed in the Preface. Some of the other designations used in these documents are also registered trademarks; the owner's rights may be violated if they are used by third parties for their own purposes.

## Impressum

Editor and Publisher: A&D PT1

### Copyright © Siemens AG 1999 All rights reserved

The reproduction, transmission or use of this document or its contents is not permitted without express written authority. Offenders will be liable for damages. All rights, including rights created by patent grant or registration of a utility model or design, are reserved.

Siemens AG,  
Automation & Drives  
SIMATIC Human Machine Interface  
A&D PT1 D1  
Postfach 4848, D-90327 Nuernberg

### Disclaimer of Liability

We have checked the contents of this manual for agreement with the hardware and software described. Since deviations cannot be precluded entirely, we cannot guarantee full agreement. However, the data in this manual are reviewed regularly and any necessary corrections included in subsequent editions. Suggestions for improvement are welcomed.

Technical data subject to change.  
©Siemens AG 1999

# Preface

## Purpose

This equipment manual provides operators, fitters, configurers and system support engineers with information about the functionality and technical design of the OP3.

## Organization of the manual

The equipment manual *Operator Panel OP3* is organized into five parts:

Part	Chapters	Contents
I	1 - 2	Overview of the Operator Panel and range of functions in tabular form.
II	3 - 4 5 - 11 12	How to operate the OP3. Step-by-step instructions on how to operate the Operator Panel using the standard screens. Information on how to connect the OP3 to the SIMATIC S7.
III	13 - 14	– Mechanical and electrical installation, – Commissioning
IV	15 - 16	– Dimensions and connection elements, – Test and monitoring functions
V	Appendix	– Brief descriptions of standard screens, – System messages, – Technical data, – ESD guidelines, – SIMATIC HMI documentation, – Glossary of technical terms.

## Conventions

The following conventions are used in this manual:

<code>Motor off</code>	Text on the display of the OP3 is shown in "typewriter" style.
<i>Variable</i>	Symbolic names representing variable values on the display of the OP3 are shown in italic "typewriter" style.
<i>System</i>	Functions which you can choose are shown in normal italics.
<i>System</i> → <i>Mode</i>	Steps that are performed in succession are linked by an arrow.
ESC	The names of keys are shown in a different type.

## History

The various releases of the equipment manual correspond to the following firmware and ProTool versions:

Release	Remarks	ProTool version
07/95	First release of the OP3 equipment manual	V 2.0 and later
08/96	Technical content of the equipment manual reviewed	V 3.0 and later
11/99	Technical content of the equipment manual reviewed	V 5.1 and later

## Trademarks

The following names are registered trademarks of the Siemens AG:

- SIMATIC®
- SIMATIC HMI®
- HMI®
- ProTool®
- ProTool/Lite®
- ProTool/Pro®
- SIMATIC Multi Panel®
- SIMATIC Multifunctional Platform®
- MP 270®
- ProAgent®

**Other support** In the case of technical queries, please contact your local Siemens in the subsidiaries and branches responsible for your area.

**SIMATIC Customer Support Hotline** Available worldwide, at all times:

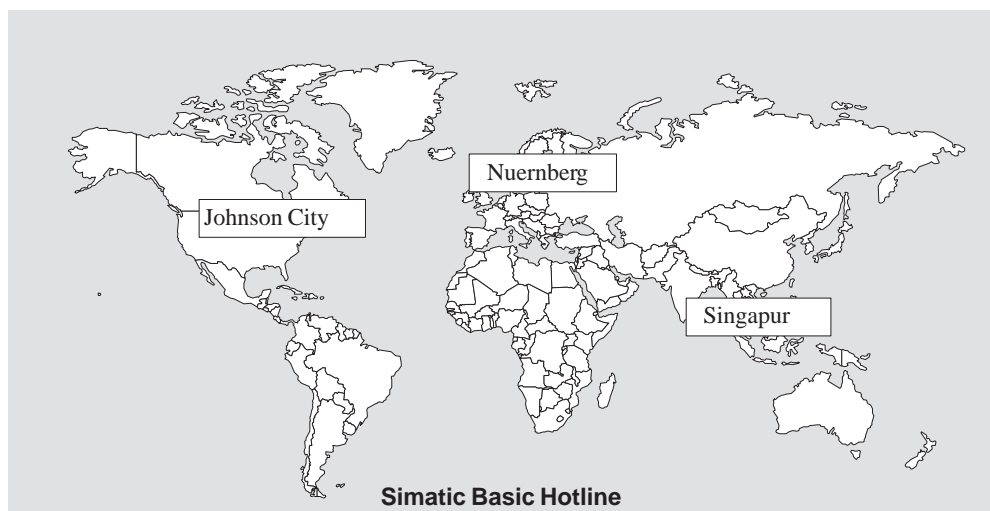

**Nuernberg**

**SIMATIC BASIC Hotline**

Local time: Mo - Fr 7:00 to 17:00

Telephone: +49 (911) 895-7000

Fax: +49 (911) 895-7002

E-Mail: [simatic.support@nbgm.siemens.de](mailto:simatic.support@nbgm.siemens.de)

**Johnson City**

**SIMATIC BASIC Hotline**

Local time: Mo - Fr 8:00 to 19:00

Telephone: +1 423 461-2522

Fax: +1 423 461-2231

E-Mail: [simatic.hotline@sea.siemens.com](mailto:simatic.hotline@sea.siemens.com)

**Singapur**

**SIMATIC BASIC Hotline**

Local time: Mo - Fr 8:30 to 17:30

Telephone: +65740-7000

Fax: +65740-7001

E-Mail: [simatic.hotline@sae.siemens.com](mailto:simatic.hotline@sae.siemens.com)

**SIMATIC Premium Hotline**

(charged, only with SIMATIC Card)

Time: Mo - Fr 0:00 to 24:00

Telephone: +49 (911) 895-7777

Fax: +49 (911) 895-7001

### **SIMATIC Customer Online Services**

SIMATIC Customer Support offers comprehensive additional information concerning SIMATIC products through its Online services as follows:

- Up-to-date general information is provided
  - in **Internet** under <http://www.ad.siemens.de/simatic>
  - via **Fax-Polling** under 08765-93 02 77 95 00
- Up-to-date product information and downloads for practical use can be found:
  - in **Internet** under <http://www.ad.siemens.de/support/html-00/>
  - via the **Bulletin Board System (BBS)** in Nürnberg (*SIMATIC Customer Support Mailbox*) under +49 (911) 895-7100

In order to contact the mailbox, please use a modem with up to 28.8 kBaud (V.34) capacity. Set the parameters as follows: 8, N, 1, ANSI, or dial for connection via ISDN (x.75, 64 kBit).

### **Abbreviations**

The abbreviations used in this equipment manual have the following meaning:

EPROM	(with UV light) erasable programmable read-only memory
RAM	Random access memory (working memory)
AM	Alarm Message
CPU	Central Processing Unit
EM	Event message
ESD	Electrostatic Sensitive Device
LCD	Liquid Crystal Display
LED	Light-Emitting Diode
MPI	Multipoint Interface (SIMATIC S7)
PC	Personal Computer
PLC	Programmable Logic Controller
PU	Programming Unit
PPI	Point to Point Interface (SIMATIC S7)
SRAM	Static Random Access Memory
OP	Operator Panel

# Contents

## Part I INTRODUCTION

<b>1</b>	<b>Product Description</b> .....	<b>1-1</b>
1.1	Configuration and Process Control Phases .....	1-1
1.2	Configuration of OP3 .....	1-3
<b>2</b>	<b>Functionality</b> .....	<b>2-1</b>

## Part II FUNCTIONS OF THE OP3

<b>3</b>	<b>General Operation</b> .....	<b>3-1</b>
3.1	Keyboard .....	3-1
3.1.1	SHIFT for Digits and Soft Keys .....	3-3
3.2	Entering Values .....	3-4
3.2.1	Entering Numerical Values .....	3-5
3.2.2	Entering Alphanumeric Values .....	3-6
3.2.3	Entering Symbolic Values .....	3-6
<b>4</b>	<b>Using the OP3 with Its Standard Functions</b> .....	<b>4-1</b>
4.1	Operating Levels .....	4-1
4.2	Standard Screens .....	4-3
4.3	Branching in Standard Screens .....	4-5
<b>5</b>	<b>Screens</b> .....	<b>5-1</b>
5.1	Screen Entries .....	5-2
5.2	Choosing Screens .....	5-3
5.3	Editing Screens .....	5-3
<b>6</b>	<b>Password Protection</b> .....	<b>6-1</b>
6.1	Password Levels and Access .....	6-1
6.2	Logging In and Out on the OP3 .....	6-2
6.3	Password Management .....	6-2
<b>7</b>	<b>Messages</b> .....	<b>7-1</b>
7.1	Event Messages .....	7-1
7.2	System Messages .....	7-3

7.3	Displaying Messages .....	7-4
<b>8</b>	<b>Timers and Counters .....</b>	<b>8-1</b>
8.1	Counters .....	8-1
8.2	Timers .....	8-2
<b>9</b>	<b>STATUS VAR and FORCE VAR with the OP3 .....</b>	<b>9-1</b>
<b>10</b>	<b>System Settings on Standard Screens .....</b>	<b>10-1</b>
10.1	Selecting a Language .....	10-1
10.2	Setting Date and Time .....	10-2
10.3	Setting Modes .....	10-2
10.4	Modifying the Address in MPI Network Configuration .....	10-3
<b>11</b>	<b>Process-Dependent Operator Guidance .....</b>	<b>11-1</b>
11.1	Branching by Means of Soft Keys .....	11-1
11.2	Self-Defined Screen Hierarchy .....	11-2
11.3	Evaluating Screen Numbers .....	11-4
11.4	System Keyboard Assignment .....	11-6
<b>12</b>	<b>Communication .....</b>	<b>12-1</b>
12.1	Connecting to an S7-200 via the PPI .....	12-2
12.2	Connecting to an S7-300 via the MPI .....	12-3
12.3	Interface Area for the SIMATIC S7 .....	12-5
12.3.1	Control and Response Bits .....	12-6
12.3.2	Connection ID .....	12-6
12.3.3	Time and Date .....	12-7

### Part III INSTALLATION AND COMMISSIONING

<b>13</b>	<b>Installation .....</b>	<b>13-1</b>
13.1	Mechanical Installation .....	13-2
13.2	Electrical Installation .....	13-3
13.3	Connecting the Configuration Computer .....	13-4
13.4	Connection to the PLC .....	13-5
<b>14</b>	<b>Commissioning .....</b>	<b>14-1</b>

### Part IV DEVICE DESCRIPTION, TEST AND MONITORING FUNCTIONS

<b>15</b>	<b>Device Description .....</b>	<b>15-1</b>
15.1	Dimension Drawings .....	15-1
15.2	Connection Elements .....	15-2



15.3	Contrast Control .....	15-4
<b>16</b>	<b>Test and Monitoring Functions .....</b>	<b>16-1</b>

**Part V APPENDICES**

<b>A</b>	<b>Brief Description of Standard Screens .....</b>	<b>A-1</b>
<b>B</b>	<b>System Messages .....</b>	<b>B-1</b>
<b>C</b>	<b>Technical Data .....</b>	<b>C-1</b>
<b>D</b>	<b>ESD Guidelines .....</b>	<b>D-1</b>
D.1	What Does ESD Mean? .....	D-1
D.2	Important Precautions against Charge .....	D-2
D.3	Handling ESDs .....	D-2
D.4	Measuring and Modifying ESDs .....	D-2
D.5	Shipping ESDs .....	D-3
<b>E</b>	<b>SIMATIC HMI Documentation .....</b>	<b>E-1</b>
	<b>Glossary .....</b>	<b>Glossary-1</b>
	<b>Index .....</b>	<b>Index-1</b>



# INTRODUCTION

# Part I

- 1 Product Description
- 2 Functionality



# Product Description

# 1

## Using the OP3

The device SIMATIC HMI OP3 allows operating states and current process values of a connected SIMATIC S7 PLC to be visualized. In addition, inputs can be made on the OP3 and written to the PLC. Functions relating to machine diagnostics can also be executed on the OP3.

The OP3 is suitable for fitting into switching cabinets and control desks, and for use as a hand-held device.

## 1.1 Configuration and Process Control Phases

### Creating data areas

Before the OP3 can go into service, it has to be prepared for its job of visualizing data from the PLC, i.e. it has to be configured. To do so, data areas used by the OP3 to communicate with the PLC have to be created in the memory of the PLC.

### Configuring with ProTool

The configuration for the OP3 is created on a configuration computer (PC/PU) using the **ProTool** configuration software. When the configuration is ready, it is transferred to the OP3. During operation, the OP3 communicates with the PLC to which it is connected and reacts to program execution on the PLC according to the configured requirements.

The following illustration depicts the configuration and process control phases:

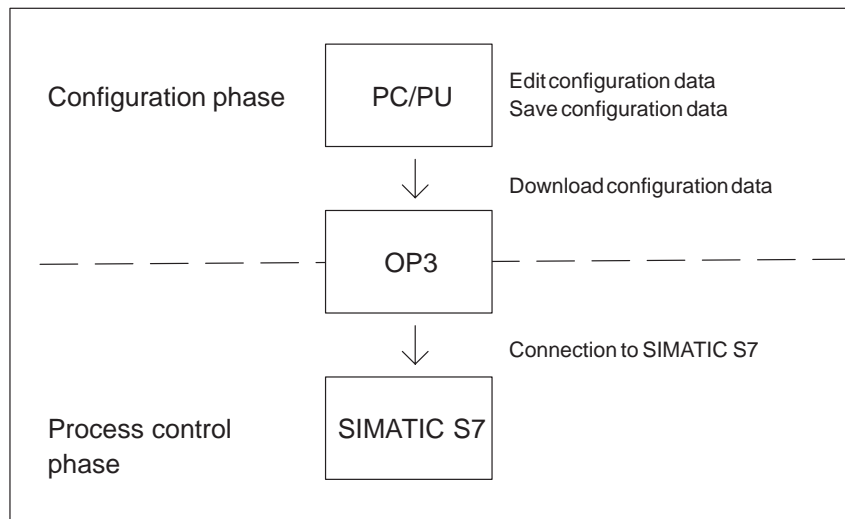

Figure 1-1 Configuration and Process Control Phases

**Static and variable sections of text**

If you wish to display text containing static and variable components, you must configure the variables and type in the static text as an explanation – for example:

`Temperature Variable_xx C of Furnace 1`

Here, `Temperature` and `C of Furnace 1` is the static text and `Variable_xx` is the variable that is read from the memory area of the PLC.

**Further information**

Information regarding configuration of the Operator Panel is provided in the *User's Guide ProTool – Configuring Text-based Displays*.

Chapter 12 tells you how to connect the OP3 to the PLC.

## 1.2 Configuration of OP3

### Display, keyboard and connections of the OP3

The keyboard and display are integrated in the top of the OP3. To the right, you will find the connections for the

- 24V power supply,
- MPI-connection,
- RS232-connection.

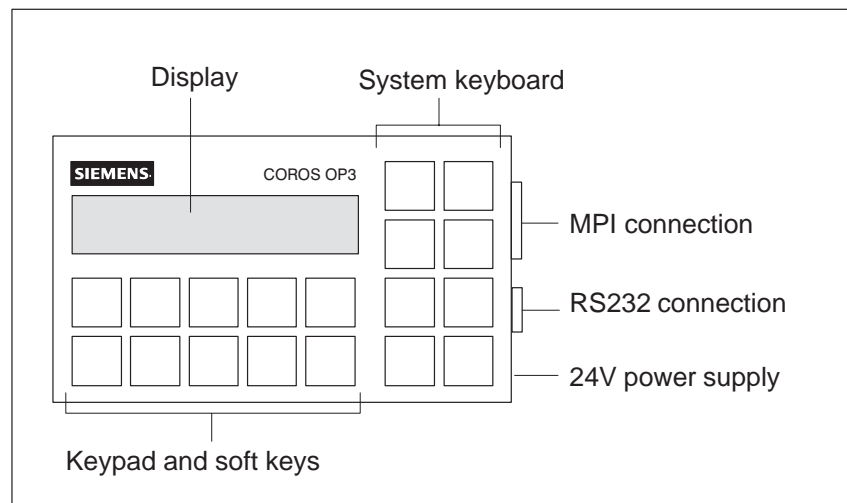

Figure 1-2 Configuration of OP3

LCD display	Display of 2 lines each containing up to 20 characters; the height of the characters is 5 mm.
System keyboard	8 keys for calling valid standard functions.
Keypad	10 keys for numeric inputs.
Soft keys	5 keys (F1 to F5) can be configured as soft keys. These keys can be configured with different functions for the various screens.
Interfaces	The OP3 has an MPI interface ( <u>M</u> ulti- <u>P</u> oint- <u>I</u> nterface) for the connection to a MPI network configuration and a RS232 interface for serial uploading configuration data.





# Functionality

# 2

## Functions and limit values

The table below shows the functions of the OP3 and their limit values.

Table 2-1 Functions of the OP3

<b>OP3 Functions</b>	
<b>Display</b> – Contrast control	Using potentiometer
<b>Event messages</b> – Maximum number – Maximum length (characters) – Scroll through waiting messages	499 40 50
<b>Setpoint input to screens</b> – Digits or letters – By means of symbolic variables	x x
<b>Actual-value display</b> (numerical and symbolic)	x
<b>Combined actual-value display/setpoint input</b>	x
<b>Limit value check by operator input</b>	x
<b>Password protection</b> – Password levels – Passwords	0 – 9 20
<b>Screens</b> – Maximum number – Screen entries per screen – Maximum number of fields per screen – Maximum number fields per screen entry – Display – Standard screens "Timer" and "Counter"	40 20 300 8 x x
<b>Diagnostic function</b> (STATUS/FORCE VAR)	x
<b>OP configuration languages</b>	GE, EN, FR, IT, SP.
<b>Changing languages in online mode</b>	3
<b>Communication using SIMATIC S7</b> – PPI – MPI	x x

Table 2-1 Functions of the OP3

<b>OP3 Functions</b>	
<b>Connection OP3 ↔ SIMATIC S7</b>	
– Number of PLCs that connect to a OP3	2
– Number of OP3s that connect to a S7-200	1
– Number of OP3s that connect to a S7-300	3

# **FUNCTIONS OF THE OP3**

# **Part II**

- 3 General Operation**
- 4 Using the OP3 with Its Standard Functions**
- 5 Screens**
- 6 Password Protection**
- 7 Messages**
- 8 Timers and Counters**
- 9 STATUS VAR and FORCE VAR Functions with the OP3**
- 10 System Settings on Standard Screens**
- 11 Process-Dependent Operator Guidance**
- 12 Communication**



## General Operation

### System keyboard and keypad

The OP3 is operated by means of the keyboard. The keyboard consists of the system keyboard and the keypad. Its configuration is shown in Figure 3-1.

### 3.1 Keyboard

#### Key functions

The system keyboard and keypad functions are described below. Keys 1 – 5 on the key pad and the +/- key on the system keyboard have dual functions.

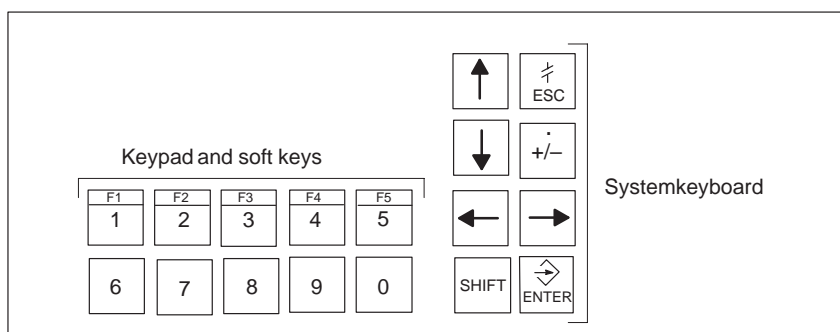

Figure 3-1 OP3 Keyboard



#### Numeric keys

Input keys for numeric characters (0 to 9).



#### Soft keys (F1 to F5)

Numeric keys 1 to 5 may be configured as soft keys, i.e. specific functions for different screens can be assigned to these keys. In operating mode, you enable soft-key functions by holding down the SHIFT key and pressing one of keys 1 to 5.



### SHIFT key

Switch to the second function of the dual-assignment keys.

To do this, the **SHIFT** key is pressed simultaneously with the other key concerned - for example:

Decimal point :      Press  + 

Soft-key function:    Press  + 



### Sign key

Change of sign from "Plus" to "Minus" and vice versa.

Second function (with pressed **SHIFT** key):  
input of a decimal point.



### ENTER key

With this key you confirm and terminate your input.

With **ENTER** you also change from message level to screen level.



### ESCAPE key

Undo:

Undoes entries in fields provided they have not been confirmed with **ENTER**.

Branch back:

Branches back from a screen to the configured cross-jump destination (by default, the last position called), or go from the start screen to message level.

Reset when scrolling through messages:

Cancels scrolling through waiting messages to reset the display to the currently waiting message.



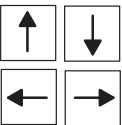

Hide a system message.



### Arrow keys

Move the cursor. Depending on the operating situation, the cursor is moved one character, field, entry or display to the left, right, up or down.

In combination with **SHIFT**:

SHIFT	+		:	Scroll up in font.
SHIFT	+		:	Scroll down in font.
SHIFT	+		:	Next position in an input field.
SHIFT	+		:	Previous position in an input field.

The numeric and arrow keys have a auto repeat function. If you keep a key pressed, your input is continually repeated after a short delay until you release the key.

### Operation Notes

If several keys are pressed in quick succession, some operator inputs may be lost. Operator inputs not accepted by the OP3 are indicated by an acoustic signal.

## 3.1.1 SHIFT for Digits and Soft Keys

### SHIFT

Depending on the configuration, you can set whether you want to assign **SHIFT** to digits or soft keys. You perform the setting in ProTool by choosing: *System* → *Settings* from the menu.

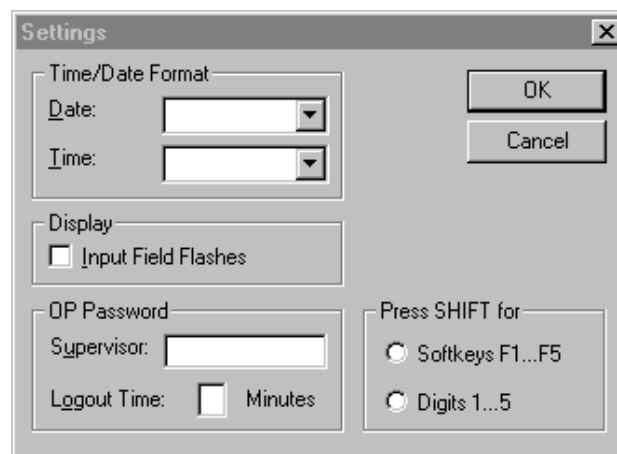

Example:

If you frequently change between screens, it is practical to assign **SHIFT** not to soft keys but to digits. For inputs, you then press **SHIFT** and the corresponding numeric key.

## 3.2 Entering Values

- General procedure** In input fields, values can be entered on the OP3 and transferred to the PLC.
1. Branch, as described in section 4.3, initially to the screen you require and then to the corresponding screen entry.
  2. Using the arrow keys, select the input field you require within the screen entry.
  3. Then enter your value. Depending on how the field has been configured, values may be input as
    - numerical values (refer to section 3.2.1),
    - alphanumeric values (refer to section 3.2.2),
    - symbolic values (refer to section 3.2.3).
  4. Confirm your input with **ENTER**.  
You can cancel any incorrect input by pressing **ESCAPE**. The original value is then automatically reinserted in the field. Then enter the correct value.
  5. Exit the screen entry by pressing **ESCAPE**.



### 3.2.1 Entering Numerical Values

#### Entering values with a decimal point

In fields that allow the operator to enter a numerical value, you enter the numerical value character by character on the keypad. You enter a **decimal point** by pressing the **SHIFT** key and the sign key simultaneously.

#### Changing numerical values

If there is a value in the field already, it is cleared completely from the field when the first character is entered. Once input has started, you cannot exit from the input field until the input has been entered or canceled.

#### Right-justified input

In numerical fields (not in hexadecimal format), input is usually right-justified. Digits that have already been entered are moved to the left (pocket calculator format).

##### **Exception:**

Input fields for setpoints in bit pattern format – for instance, when calling the PU functions **STATUS/FORCE VAR** – are changed to left-justified. When input begins, the old value does not disappear from the display completely but its bit pattern is overwritten one character at a time. You move the cursor in this type of field by simultaneously pressing the **SHIFT** key and an arrow key (← or →).

#### Limit value check

You can configure **limit values** for numerical input fields. In this type of field, a limit value check takes place. Entered values are applied only if they are within the configured limits. If a value outside these limits is entered, a system message is displayed and, after it has been canceled, the old value is displayed again.

#### Decimal places

If a numerical field has been configured with a certain number of **decimal places** and if, after you confirmed your input, too many have been entered, the extra ones are ignored; if too few have been entered, the field is fitted with zeros.

### 3.2.2 Entering Alphanumeric Values

#### Mixed input of digits and letters

In an input of alphanumeric values, digits and letters are mixed.

For the numerical components of the input, proceed as described in section 3.2.1. If, however, you wish to enter a letter at the current cursor position, you must enable the alphanumeric character set.

#### Example

To enter the string 18OCT61, for example, proceed as follows:

1. Enter 1 and 8 by means of the keypad.
2. Press the **SHIFT** key and hold it down.  
The extended character set becomes available.
3. Scroll with the **UP** or **DOWN** arrow key through the extended character set.
4. Select **O** and move right one position using the **RIGHT** arrow key.  
The character you selected is applied by moving the cursor.
5. Select **C** and move right one position using the **RIGHT** arrow key.
6. Select **T** and move right one position using the **RIGHT** arrow key.
7. Release the **SHIFT** key. The extended character set is de-activated.
8. Enter the remaining figures 6 and 1 by means of the keypad and confirm your input by pressing the **ENTER** key.

### 3.2.3 Entering Symbolic Values

#### Text instead of a value

In the case of a symbolic input of a value, text is displayed or typed instead of the value. If a field has to be filled in using a symbolic entry for a value, then apply the text from a list box. To do this, proceed as follows:

1. Press **SHIFT** in the input field and hold it down.  
The list box with its configured symbolic inputs is activated.
2. With the cursor keys, select the text you require.
3. Release **SHIFT**.
4. Confirm your selection by pressing **ENTER**.

# Using the OP3 with Its Standard Functions

# 4

## Using the standard screens

The configuration software ProTool, includes a configuration which contains standard screens. You can choose all the functions required for operating the OP3 by using these standard screens. The different functions are described in this manual with reference to the standard screens.

The English-language standard screens, which are loaded from the firmware of the OP3, remain active, once you have switched on the operating voltage, until a configuration is loaded (refer to section 4.2).

## 4.1 Operating Levels

### Message level and screen level

In OP3 operation, you have to distinguish between two distinct operating levels, between which you can switch:

- **Message level**  
At the message level, current messages are displayed.
- **Screen level**  
At the screen level, functions are chosen, serviced and executed.

The message level is the highest level on the OP3. At message level, waiting event messages and system messages are displayed. After the OP3 starts up, it changes to message level and displays the standby message.

The screen level is reached by pressing the ENTER key. The first screen to be called is the start screen. From the start screen you branch, depending on the configuration, to other screens. On the screens, you view the actual process values, and you can enter values and initiate functions by means of soft keys.

### Screen hierarchy

The linking of individual screens is referred to as a screen hierarchy. As you go further down the screen hierarchy, you go stage by stage right back to the start screen by pressing the ESCAPE key. From here you can return to the message level by pressing the ESCAPE key. You can also return directly to the message level from a screen, depending on the configuration.

## Changing operating levels

The change from screen level to message level, or back again, is either manual or automatic.

### Manual change

You press the appropriate key and change the operating level

- from message level to screen level by pressing the ENTER key,
- from screen level to message level by pressing the ESCAPE key.

You cannot branch backward from the message level by pressing ESCAPE. The key is merely designed to terminate the display of a system message at this level. Figure 4-1 shows how you switch from one operating level to the other.

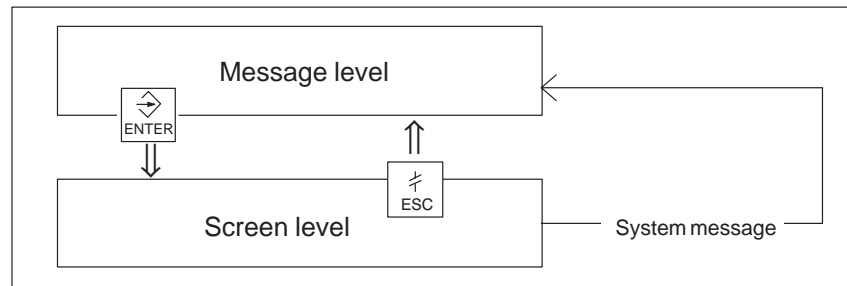

Figure 4-1 Changing between Message Level and Screen Level

### Automatic change

The OP3 returns immediately to the **temporary** message level when a message arrives. If the message is acknowledged by pressing ENTER or if it departs, the very same screen from which the OP3 branched to the message level is displayed again. If several messages arrive simultaneously, all messages are acknowledged by pressing ENTER.

All inputs not confirmed by pressing ENTER before the OP3 branched to message level are canceled.

### Operation in the temporary message level

If several messages are queuing, you can view several messages in succession by scrolling with the UP and DOWN keys. Only UP, DOWN and ENTER are allowed at the temporary message level.

### Nesting level

If you jump from one screen to another, the OP3 can retain a total of twenty jumps. You return by pressing ESCAPE.

If the nesting level of twenty screens is exceeded, the OP3 jumps – subsequent to a temporary message display – to the twentieth screen, not to last screen that was called.

## 4.2 Standard Screens

### Basic operation with standard screens

The standard screens contain functions that are fundamental to the basic operation of OP3, such as Display Screens, Modify Password and Set OP3 Operating Mode. Process-specific implementations, such as event messages or screens for the process, are not included.

### Functions on standard screens

Standard screens are called from a basic screen by means of a soft key. From the basic screen, you branch to the following screens:

- **Screens**  
At this point the screen directory is called to display screens. All the screens which were given the "directory" attribute are listed here. If you have still not created any screens of your own, the directory will contain only two standard screens, *Counter* and *Timer* (refer to chapter 8).
- **System settings**  
At this point you can modify settings in online mode. This includes, for example, choosing the OP3 mode, switching languages, or adjusting date and time.
- **Status Variable**  
At this point the PU function STATUS VAR is called; you can use it to display PLC operands.
- **Force Variable**  
At this point the PU function FORCE VAR is called; you can use it to display and modify PLC operands.
- **Password processing**  
At this point the superuser assigns the passwords for the different password levels. Furthermore, logout is included here.

Standard configurations, with ready-to-use standard screens, are supplied for the OP3 with the ProTool configuration software. Figure 4-2 shows the screen hierarchy for these standard screens. You will find comprehensive information about the functions and manipulation of the standard screens in the corresponding sections of this manual.

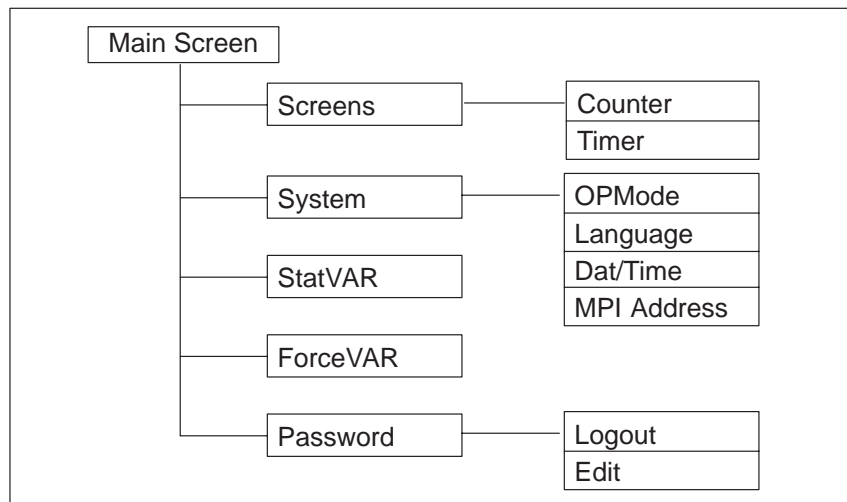

Figure 4-2 Screen Hierarchy for the Standard Configurations Supplied

### 4.3 Branching in Standard Screens

#### Branching to screen level

At screen level, you can operate and monitor the process or system by means of the corresponding screens and standard screens and perform system settings.

Taking standard screens as an example, a description is provided below of the manner in which you branch from one screen to another within the screen hierarchy.

#### Branching with soft keys

Call the *standard basic screen* in your configured screen hierarchy. Using the soft keys beneath the symbols << and >>, you can move the displayed screen segment of the active screen (scroll screen function). You can branch to the next screen by pressing the soft key beneath the screen text. A vertical line designates the assigned soft key (in Figure 4-3, soft keys F2 and F4).

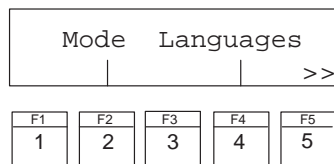

Figure 4-3 Branching at Screen Level

#### Choosing screens

You choose a screen by pressing the soft key assigned to it during configuration.

If either of the symbols << or >> is displayed at the beginning or the end of the second line on the display, you can use the screen scroll function for further selections with F1 or F5, if the entry you require is not within the visible display area.

#### Calling functions

Functions are called by means of the soft keys assigned to them during configuration.

For protection against unauthorized use, a password having a specific password level has to be entered first for some functions (refer to section 6.1).





## Screens

### Operator-process monitoring and control with screens

On the OP3, the process – for example, a bottling plant or a mixing unit – is displayed on screens and controlled. These screens are configured by the configurator for specific users.

On screens, logically associated process values are acquired and provide an overview of a process or system. In addition to this alphanumeric "imaging" of the process, screens provide a means of entering new process values and, consequently, of controlling the process. Up to 40 screens can be configured on the OP3.

Process values on a screen can be randomly assigned to subject-related groups.

#### Example:

```
Furnace1 temp. 80C
Furnace2 temp. 78C
Furnace1 cont. 12001
Furnace2 cont. 30001
Valve1 press. normal
Valve2 press. high
```

### Screen components

A screen on the OP3 consists of the following components:

- a title (optional),
- screen entries.

### Screen directory

Screens can be grouped during configuration in a screen directory, which is used to display them on the screen and also to edit them. A screen can be retrieved from its screen directory by its screen number and its screen title, if configured.

## 5.1 Screen Entries

### Displaying a screen entry

Screens consist of one or more entries. On the OP3, precisely one entry is displayed per display page. Lines which have not been fully configured are displayed as blank lines.

An example of a screen entry is

```
Furnace1 temp. 80C  
Furnace2 temp. 78C
```

### Components of a screen entry

A screen entry consists of the following components:

- entry text  
The static text contains explanations for the operator. It may also include information on how soft keys have been assigned.
- fields for the
  - output of
    - date and time,
    - actual values.
  - input of setpoints which are immediately transferred to the PLC after being entered,
  - combined I/O of PLC setpoints and actual values.
- soft keys  
Soft keys are assigned variable, screen dependent functions.

### Updating values in screen entries

The configuration defines the intervals at which PLC values are updated, i.e. read again from the PLC and displayed. The lowest configured polling time applies to the whole screen entry.

To optimize performance, you should

- configure the polling times for updating as long as possible, (at least > 1 second)
- configure short polling times only for those entries which really do have to be updated quickly.
- state only one controller per entry (max. of 2 are possible)

### I/O fields

Output fields display actual values of the PLC in numerical or symbolic form. Input fields define setpoints in numerical or symbolic form. In input fields, the flashing cursor is visible.

For symbolic I/O fields, you can configure up to 256 text elements, which you can call on the OP3 using a selection field. The value you select is applied.

With inputs of numerical values, configured number formats or limit values apply to the number of places before and after the decimal point.

## 5.2 Choosing Screens

### Methods of choosing screens

You can choose a screen by means of soft keys and/or by using the screen directory.

### Choosing with soft key

With soft keys, you can branch from one screen to another. The branch is defined in the configuration.

### Choosing with screen directory

Call the standard screen *Screens*. Thereupon the screen directory is displayed on the screen. It contains only the screens which were included in it during configuration. Enter the number of the screen you require or "scroll" in the screen directory using the arrow keys. In either case, press **ENTER** to choose the screen.

## 5.3 Editing Screens

### Procedure

You can enter values in screens. To edit a screen, proceed as follows:

1. Choose the screen you wish to edit as described in section 5.2.
2. The cursor jumps to the first input field.
3. Use the **LEFT** or **RIGHT** arrow keys to move the cursor to the field concerned.
4. Perform the modifications you wish to make as described in section 3.2.
5. After confirming your input, re-position the cursor to perform further modifications, as necessary.
6. Terminate editing – for example, by pressing **ESCAPE**.



## Password Protection

### Preventing unauthorized operation

To prevent unauthorized operation of the OP3, there is the possibility of controlling access by means of passwords and password levels for calling certain functions and inputs.

### 6.1 Password Levels and Access

#### Password hierarchy

When you are configuring on the OP3, you assign password levels from 0 to 9 for soft keys and input fields. The password levels assigned to the standard screens are listed in Appendix A.

If an operator logs on to the OP3 with a password pertaining to a certain level, he is authorized to execute functions at that password level and at lower levels.

#### Password level 0

At this level, the lowest in the hierarchy, functions are assigned which, when enabled, have little or no effect on the execution of the process; these are normally calls of functions not having input options – for example *Message Level*.

You do not have to enter a password to call password-level 0 functions.

#### Password levels 1 to 8

Levels 1 to 8 are assigned to functions of increasing importance.

#### Password level 9

Permission to execute functions of password level 9 is the sole responsibility of the superuser, who has access to all OP3 functions.

If an operator logs in with the password of a specific password level on OP3, he is authorized to execute functions at this and lower levels.

#### System administrator's password

You set the system administrator's password when you configure the system. The default setting of 100 also applies to the internal standard screens. This setting can be changed using the OP3.

## 6.2 Logging In and Out on the OP3

**Login** If a function is called on the OP3 for which the current password level is too low, you are automatically prompted on the display to enter the password. You terminate password input by pressing the **ENTER** key.

**Logout** Choose the standard screen *Password* → *Logout* to log out from the OP3. The OP3 then changes from the current password level to 0, the lowest password level, and branches to message level.

## 6.3 Password Management

**Password management authorization** Only the superuser (password level 9) is authorized to call the password management functions.

**Displaying the password list** Choose the standard screen *Password* → *Edit*. The password list is displayed (Figure 6-1).

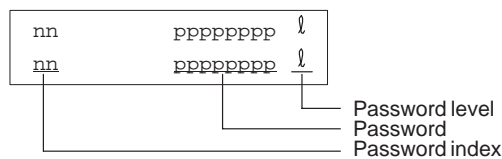

Figure 6-1 Password List

**Password index** Passwords are numbered consecutively with a two-digit password index. The fields for the password and its assigned password level are on the right of the password index. Only the superuser entry is contained in the fields when the password list is called for the first time.

If a password has not been entered for a password index, the fields for the password and the password level are shown as dashes.

You can scroll through the password list using the **UP** and **DOWN** arrow keys.

**Allocating  
passwords and  
password levels**

You can allocate up to 20 passwords. The password must contain a minimum of three and a maximum of eight digits. Leading zeros and letters are not allowed.

To allocate a password and a password level, proceed as follows:

1. Select the line for the password entry on the password list.  
The cursor is located on the first character of the field for password input.
2. Enter a password and confirm it by pressing **ENTER**.
3. Move the cursor with the **RIGHT** arrow key to the field for the password level.
4. Enter a password level of 1 to 8 for the password and confirm it by pressing **ENTER**.
5. Exit from the standard screen by pressing **ESCAPE**.

**Modifying  
passwords and  
password levels**

To modify a password, call the password entry in the same way as you would to allocate a password and enter the new password by overwriting the old one.

If you just want to modify the password level and not the password, skip the field containing the password entry by pressing **ENTER**. Then move the cursor with the **RIGHT** arrow key to the field for the password level and enter the new level.

**Deleting  
passwords**

To delete a password, call the password entry in the same way as you would to allocate and modify a password but overwrite the first character of the password with a zero. Then confirm the deletion by pressing **ENTER**.





# Messages

## Event messages and system messages

Events and states in the control process are displayed on the OP3 in message form. A message consists of static text as a minimum. It may also contain variables.

Different types of message are displayed on the OP3

- event messages and
- system messages.

Event messages are initiated by the PLC. They are configured and contain process-related information.

System messages are initiated by the OP3. They are not configured. They provide information on operating states of the OP3 or maloperations and breakdowns in communication.

## 7.1 Event Messages

### Definition

Event messages contain process-related information – for example, messages relating to states or processes such as

Temperature reached or  
Motor running.

Apart from status messages, notices to operators can also be configured as event messages. If, for example, a machine operator wants to initiate bottling but has forgotten to open the water inlet valve on the mixer, a message such as `Open water intake valve` can prompt him to rectify the error.

### Representation

Event messages can be configured so that any of their text components flash to distinguish them from message text.

Messages may contain static text and variable fields. The variable fields display, for example, current values of the PLC in numerical or symbolic form. In addition, the date and time can also be output in messages.

**Message bit procedure**

If there is a condition present in the current process that causes a message to be issued – for example, a setpoint has been reached – a bit is set by the PLC application program in the data area for event messages. The OP3 reads the data area after a configured polling time. In this way, a message is detected as having "arrived". The bit is reset by the PLC when the condition for issuing the message no longer exists. The message is then regarded as having "departed".

**Event message area**

Define an *event message area* for event messages in your configuration. In ProTool, you set the event message area by choosing *System → Area Pointer* from the menu.

You can configure a single event message for every bit that has been configured in the event message area. The event message area (up to 64 bytes) can be divided into as many as four event messages. The address areas must not be contiguous.

Figure 7-1 shows the assignment of bit numbers to message numbers for data bytes. Bit numbers are assigned automatically to message numbers on the OP3.

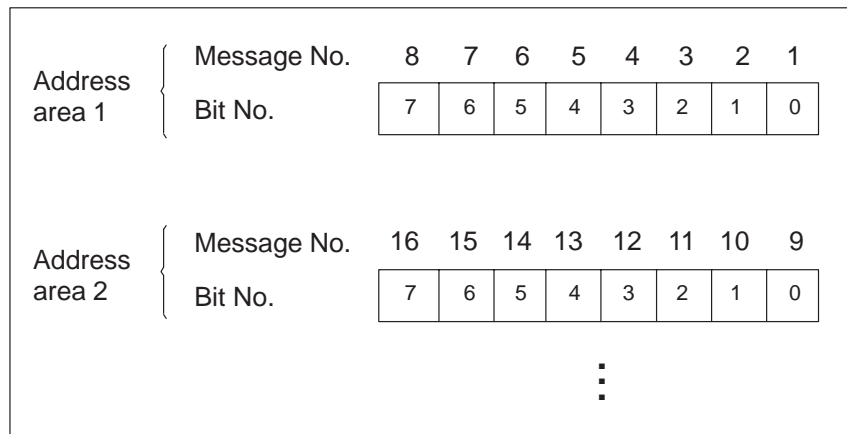

Figure 7-1 Assigning Event Message Areas and Message Numbers

**Updating messages**

When the OP3 detects a message as having arrived, it reads the value it has to display for the message variables supplied by the PLC and displays them. The fields defined in the messages are updated periodically at the configured polling time.

**Manual change of message level**

If a message departs while it is being displayed, the display is updated, i.e. the next message is shown automatically.

**Temporary message level**

If a message departs, the very same screen from which the OP3 branched to the message level is displayed again (refer to section 4.1).

**Stand-by message** The stand-by message is event message No. 0. It appears on the display when the OP3 is working at message level and event messages or system messages are not waiting. The stand-by message is stored in the firmware and contains, by default, the release and the device type:

OP3	Vx . xx
2x20 char .	5mm

Figure 7-2 Default stand-by message

Depending on the configuration, the stand-by message can be represented by other text. It can contain the date and time but not variables.

## 7.2 System Messages

**Definition** System messages indicate operating states within the OP3. For example, they draw your attention to maloperations or a breakdown in communication. This message type has top display priority. If a corresponding fault occurs on the OP3, the active event message is removed from the display and a system message is issued in its place.

After the system message is removed from the screen, the OP3 returns to the point from which it branched to message level.

### **Serious and non-serious system messages**

System messages are classified as serious and non-serious system messages. A serious system message is based on an error that can be rectified only by a cold or warm restart of the OP3.

All other errors generate a non-serious system message – for example, when you cannot choose a screen. Display of a non-serious system message can be canceled by pressing **ESCAPE**. But it can also be canceled automatically after a configured time.

A list of possible system messages and their explanations will be found in the appendices.

### **Inhibiting system-messages**

Display of system messages (except for internal errors 7xx) is activated or inhibited during configuration. This setting on the OP3 cannot be changed later.

### 7.3 Displaying Messages

**Display** Event messages are always output to the display at message level on the OP3 and are displayed according to display and message priorities. Messages are displayed one at a time on the OP3, even if they have been configured as single-line messages.

**Display priorities** System messages always have top display priority. Event messages are displayed according to their message priorities.

**Message priorities** During configuration, you can set message priorities from 1 (low) to 4 (high), according to their importance, within event messages.

If several messages having the same display and message priorities exist simultaneously, the most recent message is shown first:

**Example**

Table 7-1 Order of Arrival and Display of Messages

Order of Arrival	Order of Display
1. Event message A (priority 2)	1. System message A
2. Event message B (priority 3)	2. Event message D (priority 4)
3. Event message C (priority 2)	3. Event message B (priority 3)
4. System message A	4. Event message C (recent with priority 2)
5. Event message D (priority 4)	5. Event message A (older with priority 2)

**Message buffer** The OP3 message buffer stores the fifty latest messages in the order in which they arrive. When the message buffer is full, the oldest message is overwritten.

**Message shower** If there are more than fifty messages at any one time (message shower), only the fifty current messages contained in the buffer will be displayed. Any other messages that may be waiting cannot be displayed when messages depart. Upon reading the event message area, the OP3 detects only one status change of the bits. Since the bit status of waiting messages that have yet to be allowed into the buffer has not changed, the OP3 does not then detect these messages as having "arrived".

### Scrolling through Waiting Event Messages

If a system message is not being displayed, you can scroll at message level through the messages that have not yet departed. Event messages are sorted according to priority groups and are displayed in their order of arrival.

Before you can scroll through waiting messages starting from the message being currently displayed, you must first go to scroll mode using the ↓ or ↑ arrow keys:



Display of the most recent (and possibly low-priority) message. Following the oldest message in a priority group, the most recent message of the priority group having the next lowest priority is displayed. The end of the message area is marked by "↓↓↓". You cannot scroll beyond this end mark.



Display of previous (and possibly high-priority) message. Following the most recent message in a priority group, the oldest message of the group having the next highest priority is displayed. The beginning of the message area is marked by "↑↑↑". You cannot scroll beyond this start mark. The message currently waiting is displayed again by pressing ESCAPE or if the OP3 has not been operated for one minute.



# Timers and Counters

## Standard screens

With the OP3, you can access the SIMATIC S7's timers and counters. Examples of this have been implemented on the OP3 standard screens. The following description of access to timers and counters refers to the *Timer* and *Counter* standard screens. You can choose these standard screens from the screen directory on the OP3.

## 8.1 Counters

### Display/edit the counter value

For every counter that has been configured and enabled on the PLC, you can have the OP3 display the current counter status. Call the *Screens* → *Counters* standard screen. The following display appears, by way of an example:



Exit from the standard screen by pressing ESCAPE.

### Edit the counter setpoint

There is no point in entering counter setpoints, since the values are overwritten by the current contents of the accumulator on the SIMATIC S7 when the counter is called.

## 8.2 Timers

### Display the actual timer value

For every timer that has been configured and enabled on the PLC, you can have the OP3 display the present actual value. For this, call the *Screens* → *Timers* standard screen. The following display appears, by way of an example:

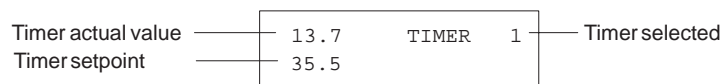

Exit from the standard screen by pressing **ESCAPE**.

### Edit the timer setpoint

There is no point in entering timer setpoints, since the values are overwritten by the current contents of the accumulator on the SIMATIC S7 when the timer is called.

### Time base

The time base of the timer depends on which PLC has been configured:

**SIMATIC S7-200:** Every timer has a permanent time base with a permanently configured number of digits behind the decimal point. Timer values are displayed in seconds on the OP3.

**SIMATIC S7-300:** The common time base for the timers can be configured (10 ms, 100 ms, 1 s or 10 s). The OP3 detects the time base which you set and standardizes the displayed value to seconds.



# STATUS VAR and FORCE VAR with the OP3

# 9

## Access to PLC operand values

With its PU functions STATUS VAR and FORCE VAR, the OP3 provides means of displaying and modifying operand values supplied by a connected PLC by means of standard screens. In online mode, this means that PLC operands can be edited directly on the OP3 without having to connect a programming unit or a PC to the PLC.

STATUS VAR can be used only to display SIMATIC S7 operands.

FORCE VAR is used to display the SIMATIC S7 operands and to modify their variable values and to transfer them back to the PLC.

## MPI address

After the functions STATUS VAR or FORCE VAR have been called, OP3 prompts you to type in the MPI address of the PLC. The default value is address 2. You can select any SIMATIC S7 on the MPI network, even those that have not been configured.

In this way, one further, dynamic connection is possible from the OP3 to a SIMATIC S7 on the MPI network, in addition to a maximum of two permanent, configured connections.

## FORCE VAR STATUS VAR

You call FORCE VAR by means of the standard screen *ForceVAR*. You call STATUS VAR by means of the standard screen *StatVAR*. Figure 9-1 illustrates, by way of an example, how PLC operands are displayed on the OP3.

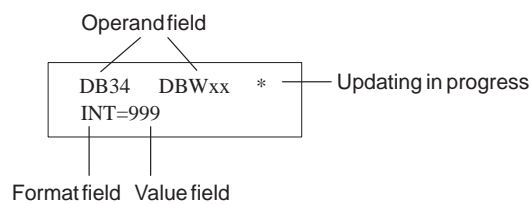

Figure 9-1 Example of PLC Operand Display

**Key functions**

After typing in the MPI address, you go to the operand field using the → arrow key. Hold down SHIFT and select the data type you wish to have displayed using the ↑ or ↓ arrow key. Pressing ENTER automatically sets the corresponding data format in the format field.

Use the → key to go to the numeric field. Using the keypad, type in the number of the operand you wish to display or modify and press ENTER to confirm.

The cursor can be moved horizontally within the lines and value fields. A total of 10 lines can be assigned. Confirm inputs one field at a time by pressing ENTER. The values of the operands you select are displayed in the value field in the specified format.

Single lines can be deleted by using the key combination SHIFT + ESCAPE.

When you have finished editing the operand list, the values on the PLC have to be updated. This is not done immediately after an individual value has been confirmed. Not until you press the ENTER key again after confirming the final value are the new values transferred to the PLC. During updating, a flashing asterisk \* is displayed in the top right corner of the display. If the asterisk does not flash, this means that a logical link has not been established to the PLC. Inputs cannot be made while updating is in progress. Updating can be canceled by pressing ESCAPE.

No inputs can be made while updating is in progress. You can abort updating by pressing ESCAPE.

**Authorized data formats**

The table shows the data formats authorized for the SIMATIC S7-200 and S7-300.

Address	Data Format
<b>SIMATIC S7-200</b>	
V	WORD
I	
O	
F	
T	TIMER
C	COUNTER
<b>SIMATIC S7-300</b>	
DB, F	WORD TIMER COUNTER
I, PI, O, PQ	WORD
T	TIMER
C	COUNTER

# System Settings on Standard Screens

# 10

**In this chapter** This chapter describes functions relating to system settings which can be executed by means of standard screens.

## 10.1 Selecting a Language

**Online selection of three languages** Messages and screens can be displayed in several languages. Up to three of the languages listed below can be loaded simultaneously on the OP3 and presented to the operator for selection in online mode:

- German,
- English,
- French,
- Italian,
- Spanish.

**Procedure** To choose another language, proceed as follows:

1. Choose the standard screen *System* → *Language*.
2. Select the language you require by means of a symbolic input. The list of options contains only the languages which have been loaded on the OP3.
3. The OP3 performs a cold start and loads all elements of language-dependent text in the new language.

## 10.2 Setting Date and Time

### Changing the date and time

You can adjust the current date and time on the OP3. The day of the week is calculated internally. Any change you make will affect all messages and screens from which a date or time variable is displayed. The display format for date and time is defined in your configuration and cannot be modified on the OP3.

### Procedure

1. Choose the standard screen *System* → *Dat/Time*.  
Use the arrow keys to move the cursor from the date field to the time field and back again. To move the cursor within the input field for the date or the time, hold down **SHIFT** and press the **LEFT** or **RIGHT** arrow key.
2. Confirm your input by pressing **ENTER**.
3. Close the standard screen by pressing **ESCAPE**.

---

### Note

The OP3 does not have a hardware clock. Since the date and time are generated by software, this information has to be updated every time the OP3 starts up.

---

## 10.3 Setting Modes

### Settings with standard screens

You can set the Online, Offline, Transfer and MPI Transfer modes on the OP3 by means of a standard screen.

### Online

In Online mode, there is a logical link between the OP3 and the PLC, or the OP3 attempts to establish a link.

### Offline

In Offline mode, a logical link does not exist between the OP3 and the PLC. The OP3 does not even attempt to establish a link and variables are not updated.

### Serial Download

In serial Download mode, data are downloaded from your PU or PC to the OP3. In this instance there is no logical link between the PLC and the OP3. You cannot operate the OP3 while the download operation is in progress.

### MPI Download

In MPI Download mode, data are downloaded to the OP3 over the MPI network. In this instance there is no logical link between the PLC and the OP3. You cannot operate the OP3 while the download operation is in progress.

- Procedure** To set the modes, proceed as follows:
1. Choose the standard screen *System* → *Mode*.
  2. Set the mode you require by means of a symbolic input.
  3. After you confirm your input by pressing ENTER, a warm restart is performed.

## 10.4 Modifying the Address in MPI Network Configuration

**Settings with standard screens** You can set and modify the address of the OP3 in the MPI network configuration by means of a standard screen. To do so, proceed as follows:

- Procedure**
1. Choose the standard screen *System* → *MPI Address*.
  2. Modify the OP address and, if necessary, the baud rate.
  3. After you confirm your input by pressing ENTER, a warm restart is performed.



## **Soft keys and screen hierarchies**

Different actions are normally required or allowed in different operating situations. To support changing requirements during process control, you can configure the following measures, which provide the operator with help depending on the situation and aims:

- screen-dependent soft keys and
- user-defined screen hierarchies.

## **11.1 Branching by Means of Soft Keys**

### **Soft keys: function keys with different functions**

You can configure function calls on the OP3 by means of soft keys. Soft keys are special function keys to which different function calls are assigned for different screen entries while you edit a screen. This makes it possible for the operator to select functions as and when required by the situation. The keys that can be assigned as soft keys on the OP3 are F1 to F5.

The functions that can be assigned to soft keys include:

- display message level,
- choose screen,
- display screen directory,
- display special screen,
- logout.

When the OP3 is connected to a PLC, a bit can be configured in a variable for every soft key. This means that a bit is set in the PLC when a soft key is pressed.

## 11.2 Self-Defined Screen Hierarchy

### Defining the screen hierarchy

The screen hierarchy can be adapted to system-specific requirements and be modified either in part or in whole. Screens can be removed or added.

Screens can be linked together in random order. The configuration, sequence of the link, inclusion in the screen directory and the relevant cross-jump destinations are defined during configuration with ProTool/Lite.

### Branching with soft keys and cross-jump destinations

You branch between the different screens by means of soft keys and configured cross-jump destinations. You can branch repeatedly to the same screen. This is illustrated in figure 11-1 by screens 4 and 6. Cross-jumps are not restricted to screen level, but can branch to the message level too.

### Definition of the start screen

Another feature that is configured is the picture you want to have displayed on the OP3 as your start screen.

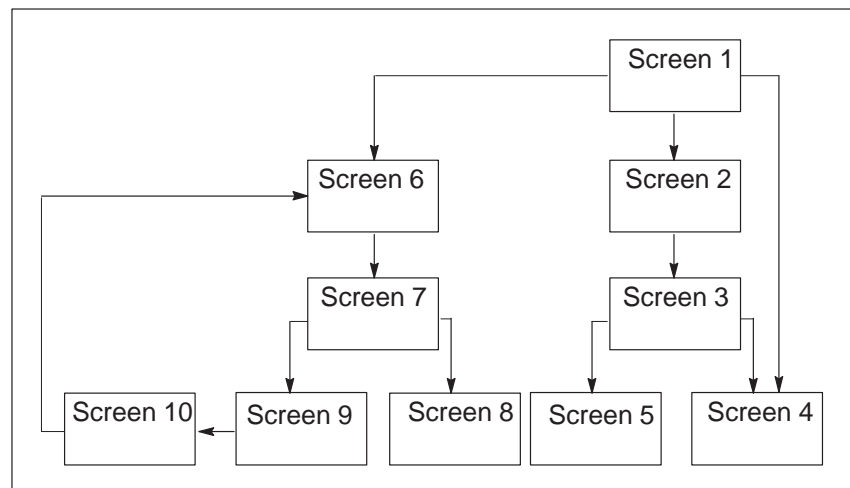

Figure 11-1 Principle of a Screen Hierarchy

An overview is presented below, with reference to an example, of the design of a screen hierarchy. Detailed information on configuration will be found in the *User's Guide ProTool – Configuring Text-based Displays*.



**Example**

The OP3 is used to operate and monitor a system for producing and bottling different fruit juices. The system consists basically of a mixing unit and a bottling machine.

**Mixing unit**

The ingredients for the fruit juices are contained in three tanks. Depending on the juice that you wish to manufacture, ingredients are mixed in certain ratios.

**Bottling machine**

After it has been mixed, the fruit juice flows into the bottling tank after a valve has been opened and is then bottled in the correct quantities. The bottles are conveyed on a belt. Before being filled, they are checked for breakages. After they have been filled, the bottles are capped, labeled and transferred to pallets.

The configured basic screen might be as shown in figure 11-2. It consists of static text only.



Figure 11-2 Start Screen of the System (Example)

The screen segment on the display can be moved horizontally with the soft keys beneath the symbols << and >>.

Pressing the soft key beneath the *Mix* entry allows you to view the entry shown in figure 11-3. It similarly consists only of static text which refers to other screens (*Tank2*, *Tank3* and *Mixer*).



Figure 11-3 Screen with Static Text (Example)

If you press the *Tank2* soft key, the entry shown in figure 11-4 appears. This entry contains static text and an output field (*Tank Contents*) and an input field (*Valve Position*). The position of the tank valve can be set in the input field by means of a symbolic value input – for example, *OPEN* or *CLOSED*).



Figure 11-4 Screen with Input and Output Fields (Example)

### 11.3 Evaluating Screen Numbers

**Application**

The screen number area is located on the PLC. The OP3 writes the number of the current screen to this area. If the PLC writes a screen number to the screen number area, the screen is opened on the OP3. You can configure operator guidance in this way.

**Configuring screen number area**

If the screen number area is to be used, it must be specified during configuration as the area pointer and created on the PLC. Figure 11-5 shows the construction of the screen number area.

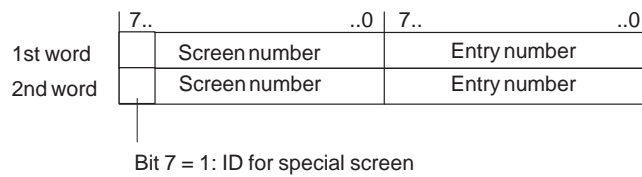

Figure 11-5 Construction of the Screen Number Area on the PLC

The screen number area consists of two consecutive data words. The first data word is used by the OP3 to store information about the display contents (screen number and entry number).

If the PLC stores screen numbers and entry numbers in the second data word, the display of a specific screen or a specific screen entry is initiated on the OP3.

The hexadecimal value FFFF in the first or the second data word indicates the message level; a value of 0 in the second data word indicates enabling of OP3 operation.

**Automatic change to message level**

0xFF is written to the screen number area when the OP3 jumps to message level; on its return, the number of the last screen called is sent once more.

### Special Screens

If the most significant bit has been set in the data word (=1), the screen number refers to a special screen. If the most significant bit has not been set (=0), the screen is a user-defined screen.

The screen numbers of the special screens are listed in the table below. An offset of 128 (most significant bit = 1) has to be added to these screen numbers.

Screen No.	Special Screen
0	Screen directory
25	Status Variable
26	Force Variable
30	Language selection
31	Changing the operating mode
35	Set time/date
36	MPI address/ baud rate
55	Password login
56	Password edit

### Screen selection via the controller

The procedure for selection of screen 5 by the PLC is described below:

- A screen is open on the the OP3.

	Screen No.	Entry No.
1st word	x	x
2nd word	x	x
- Before the application program enters the value 5 in the second word of the screen number area, it has to set the screen number briefly to 0 ...

	Screen No.	Entry No.
1st word	x	x
2nd word	0	x

... and enter the value 5 following a polling cycle at the earliest (1 second).

	Screen No.	Entry No.
1st word	x	x
2nd word	5	x
- The OP3 detects the change from 0 to 5 and opens screen 5.

	Screen No.	Entry No.
1st word	5	
2nd word	5	

## 11.4 System Keyboard Assignment

### Application

Create a data area for your system keyboard on the PLC. When you press a key, the corresponding bit is set in the keyboard assignment. The bit is set for as long as the corresponding key is pressed. Releasing the key resets the bit.

By an evaluation of this area, the operator's attention can be drawn, for example, by means of an event message to incorrect operation of a key.

### Configuring system keyboard assignment

If the data area for system keyboard bits is to be used, it must be specified during configuration as the area pointer and created on the PLC. The system keyboard assignment is a data area having a fixed length of two data words. Figure 11-6 shows its configuration for an OP3.

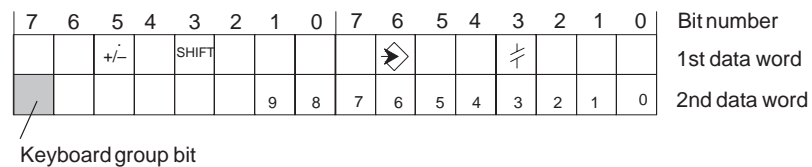

Figure 11-6 Keyboard Assignment for the OP3

The keyboard assignment is transferred spontaneously to the PLC whenever a modification is registered on the OP3. There is therefore no need to configure a polling time.

The keyboard group bit is used as a check bit. It is set to 1 every time the keyboard assignment is transferred from the OP3 to the PLC and should be reset after the data area has been evaluated by the application program. Regular reading of the group bit makes it possible to ascertain in the user's program whether the system keyboard assignment has been transferred again.

## Types of connection

The OP3 can be connected to SIMATIC S7 automation systems (PLCs) via two different network configurations. The network configuration depends on the CPU being used. The following two types of connection are possible:

- SIMATIC S7-200                      Point-to-Point Interface (PPI)
- SIMATIC S7-300                      Multi-Point Interface (MPI)  
(without CPU318)

The two different interfaces affect the configuration and the mode of addressing employed.

## User data areas

The OP3 and the SIMATIC S7 communicate via user data areas in the automation system. The user data areas you have to create on the S7 depend on the configuration. You must create suitable user data areas, depending on the objects contained in the configuration and the data to be exchanged.

For some user data areas, you must create an interface area to handle synchronization of the OP3 and the S7, if the functions contained therein are required to be used by the S7. Some user data areas are even located in this interface area.

For the OP3, the following user data areas are possible:

- Event message area (refer to section 7.1),
- Interface area for the connection ID (refer to section 12.3.2), date and time (refer to section 12.3.3),
- Screen number area (refer to section 11.3) and
- System keyboard assignment (refer to section 11.4).

---

### Note

The following is true of the user data areas:

- The system keyboard assignment and the screen number area may be created only once.
  - The interface area can be created only once for each CPU.
  - The event message area can be created multiple times on different CPUs.
-

## 12.1 Connecting to an S7-200 via the PPI

### Connection

When you are connecting an OP3 to an S7-200, connect the OP3 to the S7-200's PPI interface. In this particular instance, up to two S7-200s can be connected to the OP3.

Similarly, you can connect several OP3s to a S7-200. In this particular case, only one connection is possible at any one time from the point of view of the S7-200. The S7-200 can communicate with an OP3 and a PU in the same manner, the PU likewise being the master.

### Network configuration

In a PPI network configuration, the OP3 and the programming unit (PU) are always masters; the S7-200 is always the slave. An S7-200, however, can communicate only with one master. Figure 12-1 shows a possible network configuration. Numbers 2, 4, 1 and 3 are address examples.

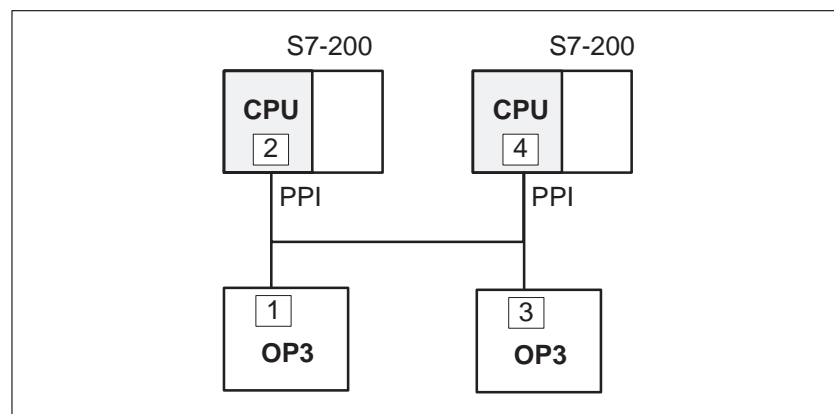

Figure 12-1 Connecting an OP3 to a SIMATIC S7-200

### Parameters

The following parameters must be set in the configuration software for a connection via the PPI:

<b>Address of the communication peer</b>	The PPI address of the S7 module to which the OP3 is connected. The default address is 2.
<b>OP address</b>	The PPI address of the OP3 in the network configuration. Any address can be assigned. It must be unique in the network configuration and may not occur more than once. The default address is 1.
<b>Interface</b>	The interface on the OP3 through which it is connected to the PPI network. The default is IF 1A.
<b>Baud rate</b>	The transmission rate at which communication takes place in the network configuration. Communication is possible at a baud rate of 9600 or 19200 bauds.

**Interface area**

If data user areas are used that are located in the interface area, you must create an interface area. You must configure a separate interface area for each S7 connected.

**Settings in ProTool**

With ProTool, all settings with the exception of the interface area must be performed by choosing *PLC*. You configure the interface areas by choosing *System* → *Area Pointer* from the menu.

**12.2 Connecting to an S7-300 via the MPI****Connection**

When connecting an OP3 to an S7-300, the OP3 is connected to the MPI interface of the S7. You can connect up to two S7s to an OP3. Up to three OP3s can communicate with an S7 simultaneously. The CPU determines the maximum number of connections. A maximum of 32 nodes can communicate in an MPI network configuration.

**Network configuration**

Figure 12-2 shows a possible network configuration. Numbers 1, 2, etc. are address examples. The address mode of the S7 is configured by means of *S7 Configuration*.

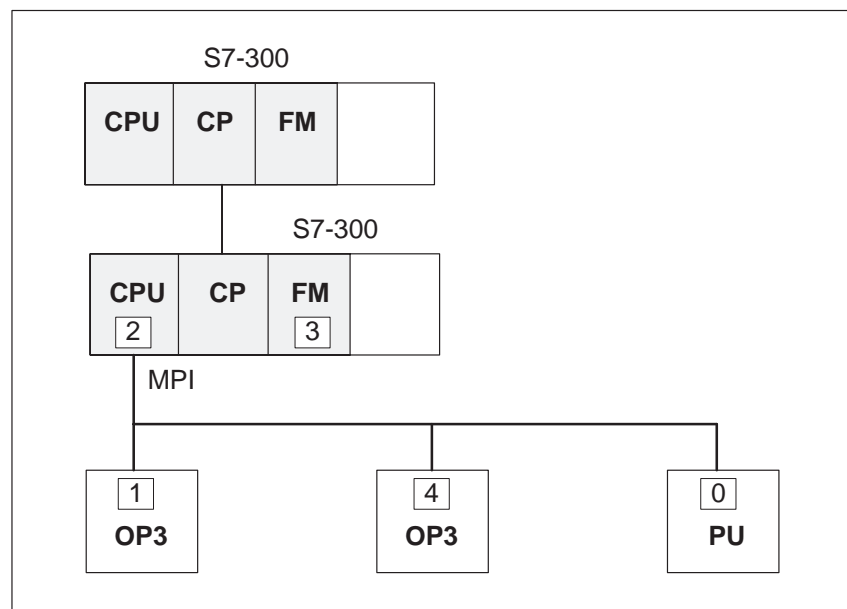

Figure 12-2 Connecting an OP3 to a SIMATIC S7-300

**Parameters**

The following parameters must be configured in the configuration software for a connection via the MPI:

<b>Address of the communication peer</b>	MPI address of the S7 module to which the OP3 is connected. The default address is 2.
<b>Expansion slot</b>	The number of the expansion slot containing the S7 module with which the OP3 exchanges data.
<b>Rack</b>	The number of the rack containing the S7 module with which the OP3 exchanges data.
<b>OP address</b>	The MPI address of the OP3 in the network configuration. Any address can be assigned. It must be unique in the network configuration and may not occur more than once. The default address is 1.
<b>HSA</b>	Highest station address. The address must be identical in the whole network configuration.
<b>Interface</b>	The interface on the OP3 through which it is connected to the MPI network. The default is IF 1A.
<b>Profile</b>	The driver profile that is used in the network configuration. Set MPI at this point.
<b>Baud rate</b>	The transmission rate at which communication takes place in the network configuration. Communication is only possible at a baud rate of 187,5 kbauds.
<b>Interface area</b>	If data user areas are used that are located in the interface area, you must create an interface area. You must configure a separate interface area for each S7 connected.

**Settings in ProTool**

With ProTool, all settings with the exception of the interface area must be performed by choosing *PLC*. You configure the interface areas by choosing *System* → *Area Pointer* from the menu.



## 12.3 Interface Area for the SIMATIC S7

### Purpose

The interface area is required only if it is intended that the following functions be used or evaluated by the SIMATIC S7:

- Synchronize the date and time of the S7 and the OP3
- Evaluate the connection ID and
- Detect OP3 start-up in the S7 program.

### Structure

Figure 12-3 shows the structure of the interface area. Where exactly you can create the interface area in the memory area of the PLC will depend upon the type of PLC you are using:

S7-200 Create the interface area in the variable memory of the SIMATIC S7-200.

S7-300 You can create the interface area in a data block or in a flag area of the SIMATIC S7-300.

Specify the address of the interface area in your configuration. This is necessary, since otherwise the OP3 will not know where the data are located.

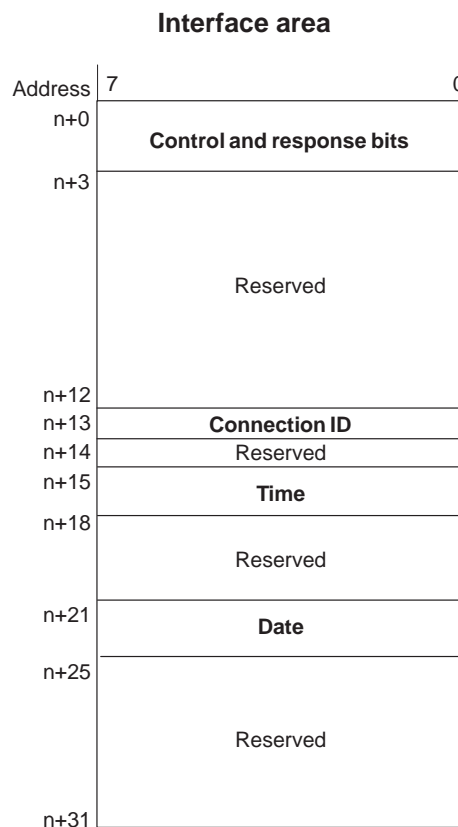

Figure 12-3 Structure of the Interface Area for the SIMATIC S7

### 12.3.1 Control and Response Bits

**Purpose**

Three bytes are present in the interface area for the control and response bytes. Bytes n+0 and n+1 are used to synchronize the OP3 and the S7. Byte n+3 is not applicable to the OP3.

**Byte n+0:**  
Requesting date and time

Byte n+0 is used by the OP3 to request the current time and the date from the S7. The illustration shows the structure of the data byte.

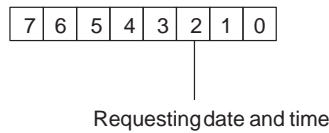

- Bit 2** Requesting date and time
- 1 = The OP3 requests the date and time every hour
  - 2 = The S7 program has updated the data and time in the interface area

**Byte n+1:**  
Detecting an OP start-up

Byte n+1 is used by the S7 to detect the OP3 restarting. The illustration shows the structure of the data byte.

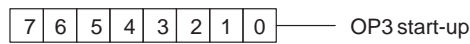

- Bit 0** 1 = The OP3 has started up

Bit 0 in data byte n + 1 is set by the OP3 upon termination of start-up. You can reset the bit in the S7 program and thus detect restarting of the OP3.

### 12.3.2 Connection ID

**Byte n+13**

The OP3 enters the connection ID (MPI/PPI) in byte n+13. This means that the connection ID can be evaluated by the S7. The illustration shows the structure of the data byte.



- 0 = Connection via the MPI
- 1 = Connection via the PPI

### 12.3.3 Time and Date

#### Purpose

The current time and date are stored by the S7 program in bytes n+15 to n+17 and n+21 to n+24. This means that the OP3 can synchronize the time and date with the S7.

#### Bytes n+15 to n+17: Time

Bytes n+15 to n+17 contain the current time of the S7 in BCD. The illustration shows the structure of the data byte.

Address	7	0
n+15	Hour (0 to 23)	
n+16	Minute (0 to 59)	
n+17	Second (0 to 59)	

#### Bytes n+21 to n+24: Date

Bytes n+21 to n+24 contain the current date of the S7 in BCD. The illustration shows the structure of the data byte.

Address	7	0
n+21	Day of week (1 to 7)	
n+22	Day of month (1 to 31)	
n+23	Month (1 to 12)	
n+24	Year (0 to 99)	

#### Synchronization with the S7

Synchronization of the OP3 and the SIMATIC S7 is performed in three steps:

1. Every hour, the OP3 sets bit 2 in data byte n+0 to 1.
2. As soon as the S7 program resets the bit, the OP3 detects that the S7 program has stored up-to-date values for the time and date in the interface area.
3. The OP3 reads the up-to-date data from data bytes n+15 to n+17 and n+21 to n+24 of the interface area.

**Reading the S7 system time**

You then transfer the S7 CPU system time to OP3. The FC6 uses the OP3 requirement in the interface area to set the OP clock.

**FC6 parameters:**

Parameter	Address	Type	Description
DBTDOP	DB51	BLOCK_DB	This is the interface area.
Set_OPTime	DB51.DBX0.2	BOOL	The first word of DB51 contains the status and control bits which display the OP3 status. The OP3 uses bit 2 to request synchronization of date and time.

Setting bit 2 of the interface area enters the current system time in the *Time* and *Date* data mailbox. The OP3 reads out the values and displays them in screens that have been configured accordingly.

**FC6 listing:**

Address	Declaration	Name	Type	Initial value	Comment
0.0	in	DBTDOP	BLOCK_DB		Number of the interface area
	out				
2.0	in_out	SET_OPTIME	BOOL		Function trigger
0.0	temp	DAT_TIME	DATE_AND_TIME		PLC time storage
8.0	temp	ret_val	INT		

**Block: FC6 CLK PLC>OP3**

Block to synchronize the OP clock with the PLC clock

Call in OB1:

```
CALL "CLK_PLC>OP3"           // FC6 call
DBTDOP      :=DB51           // DB51 = interface area in OP3
SET_OPTIME  :=DB51.DBX0.2    // DB51.DBX0.2 = OP3 requests date/
                             // time (once after OP3 restart,
                             // then every 15 minutes)
```

**Network: 1      Function trigger**

```
UN      #SET_OPTIME // as long as SET_OPTIME = 0
BEB     // do not edit block
```

Network: 2 Enter PLC time in DAT_ZEIT		
CALL	"READ_CLK"	// with SFC 1 save SFC1 // PLC time — Read System Clock
RET_VAL	:=#ret_val	// in DAT_TIME
CDT	:=#DAT_TIME	

Network: 3 Load time in OP3		
OPN	#DBTDOP	
L	LB 3	// Hours from DAT_TIME
T	DBB 15	// in interface area byte 15
L	LB 4	// Minutes from DAT_TIME
T	DBB 16	// in interface area byte 16
L	LB 5	// Seconds from DAT_TIME
T	DBB 17	// in interface area byte 17
L	LW 7	// Shift milliseconds from DAT_TIME
SLW	4	
SRW	4	
T	LW 7	
L	LB 7	// Weekday from DAT_TIME
T	DBB 21	// in interface area byte 21
L	LB 2	// Day from DAT_TIME
T	DBB 22	// in interface area byte 22
L	LB 1	// Month from DAT_TIME
T	DBB 23	// in interface area byte 23
L	LB 0	// Year from DAT_TIME
T	DBB 24	// in interface area byte 24

Network: 4 Reset all		
R	#SET_OPTIME	// Reset trigger bit
BEA		

### Setting the S7 system time

To set the S7 CPU system time from the OP, you must write the date and time in the corresponding fields in your project and set bits 5 and 6 of the interface area to 1. FC7 reads out the entered values and sets the PLC system clock.

#### FC 7 parameters:

Parameter	Address	Type	Description
DBTDOP	DB51	BLCOK_DB	This is the interface area.
NEW_TIME	DB51.DBX0.5	BOOL	Trigger from the OP to synchronize the time.
NEW_DATE	DB51.DBX0.6	BOOL	Trigger from the OP to synchronize the date.

**FC 7 listing:**

Address	Declaration	Name	Type	Initial value	Comment
0.0	in	DBTDOP	BLOCK_ DB		Number of the interface area
	out				
2.0	in_out	NEW_ DATE	BOOL		<i>New date</i> bit from interface area.
2.1	in_out	NEW_ TIME	BOOL		<i>New time</i> bit from interface area.
0.0	temp	DAT_TIME	DATE_ AND_ TIME		PLC time storage
8.0	temp	ERROR_ SFC	INT		SFC error code

**Block: FC7 CLK OP3>PLC**

Block to synchronize the PLC clock with the OP clock

Call in OB1:

```

CALL "CLK_OP3>PLC"           // FC7 call
DBTDOP      :=DB51           // DB51 = interface area in OP3
NEW_DATE    :=DB51.DBX0.5   // New date bit from the
                             // interface area.
NEW_TIME    :=DB51.DBX0.6   // New time bit from the
                             // interface area.
    
```

**Network: 1      Wait until time or date has been entered in  
DBTDOP from OP3**

```

U      #NEW_DATE    // if new date bit = 1
SPB    DAT          // Go to new date
U      #NEW_TIME    // if new time bit = 1
SPB    CLK          // Go to new time
BEA    CLK          // do not edit block further
    
```

Network: 2		New date	
DAT OPN	#DBTDOP		
CALL	"READ_CLK"	// read current time	
		// SFC1	— Read System Clock
RET_VAL	:=#ERROR_SFC		
CDT	:=#DAT_TIME		
L	DBB 21	// Load weekday from DBTDOP	
T	LB 7	// in DAT_TIME	
L	DBB 22	// Load day from DBTDOP	
T	LB 2	// in DAT_TIME	
L	DBB 23	// Load month from DBTDOP	
T	LB 1	// in DAT_TIME	
L	DBB 24	// Load year from DBTDOP	
T	LB 0	// in DAT_TIME	
SPA	SET		

Network: 3		New time	
CLK: OPN	#DBTDOP		
CALL	"READ_CLK"	// Read current time	
		// SFC1	— Read System Clock
RET_VAL	:=#ERROR_SFC		
CDT	:=#DAT_TIME		
L	DBB 15	// Load hours from DBTDOP	
T	LB 3	// in DAT_TIME	
L	DBB 16	// Load minutes from DBTDOP	
T	LB 4	// in DAT_TIME	
L	DBB 17	// Load seconds from DBTDOP	
T	LB 5	// in DAT_TIME	
SPA	SET		

Network: 4		Set PLC clock with SFC 0	
SET: CALL	"SET_CLK"	// With SFC 0 read time from DAT_TIME	
		// SFC0	— Set System Clock
PDT	:=DAT_TIME	// Save in PLC clock	
RET_VAL	:=#ERROR_SFC	// Save any errors in ERROR_SFC	

Network: 5		Reset all	
OPN	#DBTDOP		
L	0	// Reset all used data	
T	DBW 15	// areas	
T	DBW 17		
T	DBW 21		
T	DBW 23		
SET			
R	#NEW_DATE		
R	#NEW_TIME		





# **INSTALLATION AND COMMISSIONING**

# **Part III**

- 13 Installation**
- 14 Commissioning**



## Installation

### Mounting location and requirements

The OP3 is suitable for control cabinets and consoles. For this, the front panel must be provided with a mounting cutout (refer to section 15.1). The front panel must not be thicker than 4 mm. No other drilled holes are required for mounting.

The OP3 can also be used externally as a portable device.



---

### Caution

- Before the device is taken into service, it should be at room temperature. In the event of moisture condensation, do not switch on the device until it is completely dry.
- The device underwent function testing before being delivered. Should a fault still occur, enclose an exact description of the fault with the device when you return it.
- To prevent overheating of the OP3 in operation,
  - the device must not be exposed to direct sunlight (this also prevents fading of the foil front) and
  - the ventilation slits in the device housing must remain free after mounting.
- Certain parts of the system which may be carrying dangerous current are accessible after the system cabinet is opened.

---

### Note

The IP65 degree of protection can be insured only when the gasket on the front panel on the OP3 fits properly.

---

### 13.1 Mechanical Installation

#### Installing the OP3

Insert the OP3 from the front into the prepared cutout. To do this, proceed as follows:

1. Remove three screws on the rear of the housing (Figure 13-1).
2. Pull the two sections of the housing carefully apart.
3. Stick the three enclosed self-adhesive spacing rings onto the appropriate screw drill holes in the interior of the housing back panel:

Use	for Metal Thickness
No ring	To 0.3 mm
One ring	0.3 mm to 1,5 mm
Two rings	1.5 mm to 4 mm

4. Push the enclosed seal over the front part of the housing.
5. Push the parts of the housing on both sides of the mounting cutout back over one another.
6. Screw both sections of the housing together with three screws. Make sure the gasket on the front panel fits properly.

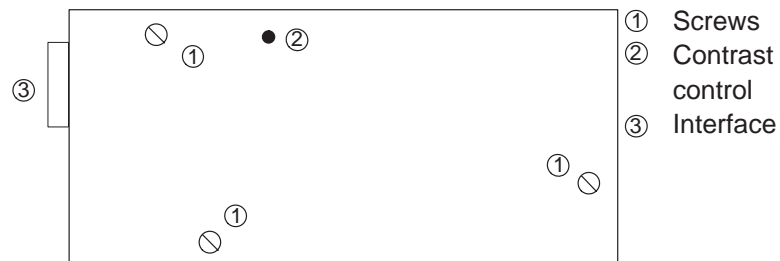

Figure 13-1 Rear of the OP3 Showing Screw Connections

After mounting, the contrast control should remain accessible for adjusting the contrast of the display.

The whole area of the OP3 is covered with a protective foil. You can remove the foil once the OP3 has been installed. OP3 functionality is also guaranteed with the foil left on, however; further, the foil protects the device from contamination.

## 13.2 Electrical Installation

### Electrical connections

The OP3 requires electrical connections to the

- power supply,
- configuration computer (PC or programming unit),
- PLC.

The electrical connection for the power supply is necessary only if the OP3 is not connected through the MPI interface to a SIMATIC S7 PLC. The electrical connection to the configuration computer is required only for transferring the configuration to the OP3.

The SIMATIC S7 controller is connected through the MPI interface integrated in the OP3. Coupling to the configuration computer is established either through the MPI interface, with downloading via the MPI, or through the RS232 interface, with serial downloading.

### EMC-compatible design

Requirements for interference-free operation are EMC-compatible hardware design of the PLC and the use of interference-proof cables.

The guidelines for interference-proof design of your PLC apply similarly to the design and installation of the OP3.



---

#### Caution

- Only screened cables are authorized for all signal connections.
  - All connectors should be screwed or locked.
  - Signal lines must not be run in the same shaft as power cables.
-

### 13.3 Connecting the Configuration Computer

#### Connection configuration diagram

Figure 13-2 shows you how to connect the OP3 to the configuration computer. The cabling of the connections shown in the figure are supplied with the OP3.

To download the configuration, you must first energize the OP3 by means of a plug-in power supply unit (refer to Section 15.2) or by using the 24V power supply cable supplied with it.

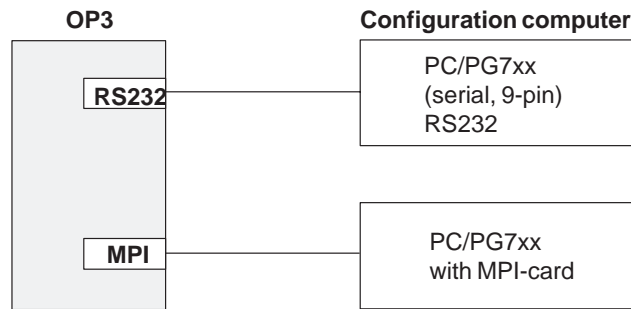

Figure 13-2 Connection Configuration Diagram for a Configuration Computer

#### Configuring via the MPI network

In addition to the methods of connection shown in figure 13-2, the configuration can also be downloaded to the OP3 when the OP3, PC or PU and S7 are operated in a common MPI network. In this case, the OP3 does not require an external power supply.

## 13.4 Connection to the PLC

### Connection configuration diagram

Figure 13-3 shows you how to connect the OP3 to the SIMATIC S7. The cabling of the connections shown in the figure are supplied with the OP3.

When the OP3 is connected via an S7 bus connector (not supplied with the OP3), the OP3 must be energized by means of a plug-in power supply unit (refer to Section 15.2) or by using the 24V power supply cable supplied with it.

No terminal resistor is required for the OP3.

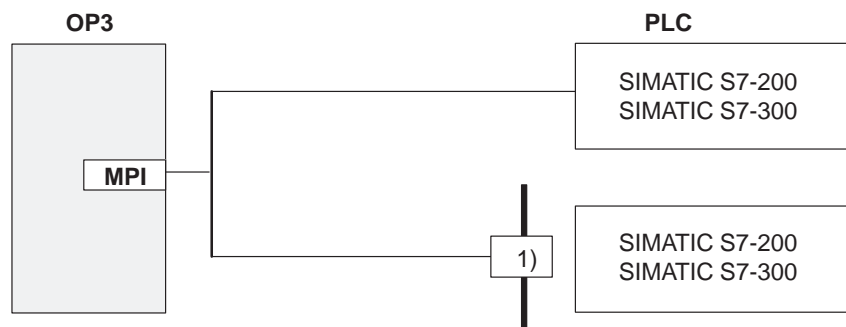

1) SIMATIC S7 bus connector for SINEC L2-DP with PU connection

Figure 13-3 Connection Configuration Diagram for a PLC





## Commissioning

### Diagrammatic representation

Figure 14-1 shows the most important commissioning steps for initial startup, restarting and normal operation of the OP3. This is followed by an explanation of the different steps for taking the OP3 into service.

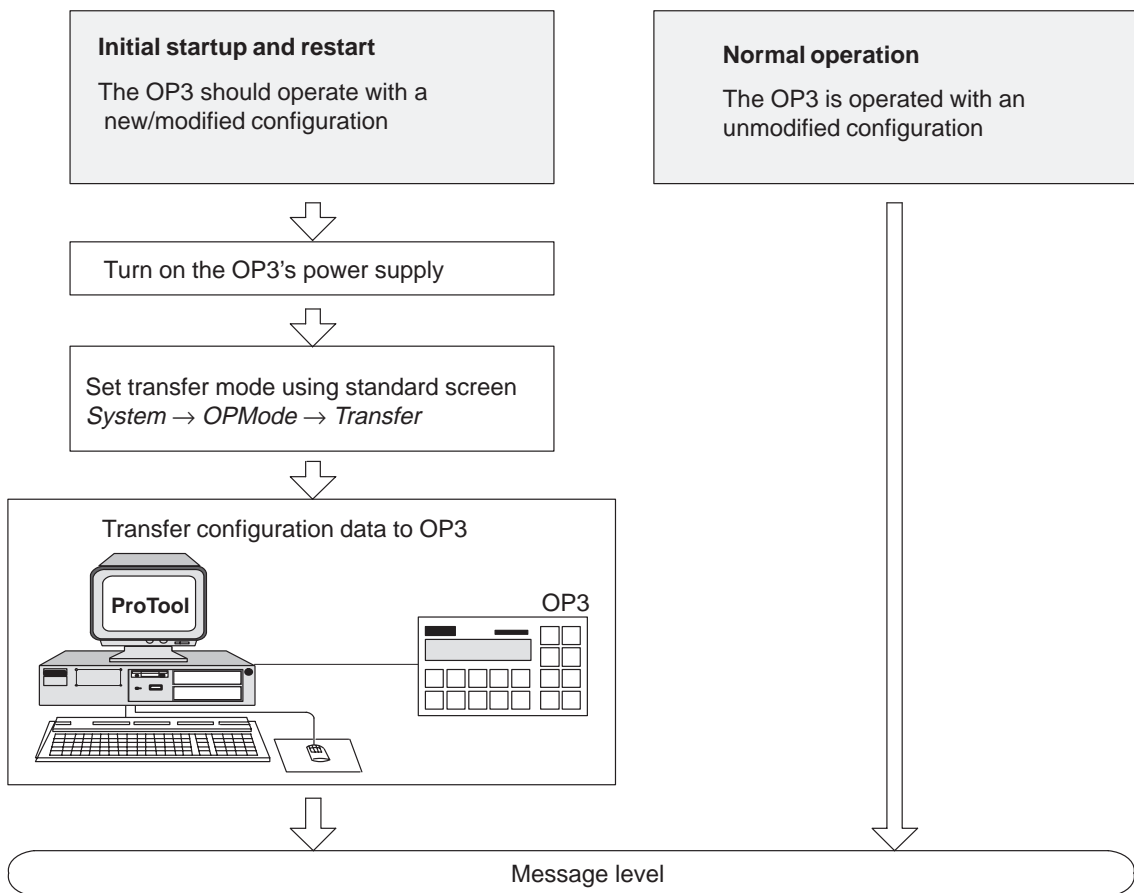

Figure 14-1 Commissioning

**Initial  
Commissioning**

During initial commissioning, the configuration required for operation is downloaded from the configuration computer to the OP3. This can be done either by using the RS232 interface or the MPI. For the MPI, the configuration computer – that is, a PC or PU – must be equipped with an MPI card.

When initially commissioning the OP3, proceed as follows:

	RS232	MPI		
1.	<p>Connect the RS232 interface of the OP3 to the COM1/2 serial interface of your PC or PU.</p> <p>To do this, use the serial connecting cable supplied with the OP3.</p>	<p>Interconnect the MPIs of the OP3 and the PC or PU.</p> <p>To do this, use the MPI connecting cable supplied with the OP3.</p>		
2.	<p>When connecting via the S7 bus connector, connect the power supply to the OP3. To do this, use either the 24-V power supply cable supplied with the OP3 or one of the two plug-in power supply units referred to in Section 15.2.</p>			
3.	<p>After the power supply has been turned on, the OP3 performs a self-test and loads the English-language standard screens from its memory. The OP3 then goes to message level.</p>			
4.	<p>Call standard screen <i>System</i> → <i>OPMode</i> and select the mode</p> <table border="1" style="width: 100%; border-collapse: collapse;"> <tr> <td style="text-align: center;"><i>Transfer</i></td> <td style="text-align: center;"><i>MPI-Trans</i></td> </tr> </table> <p>The OP3 prompts you to enter the system administrator's password (default: 100) and waits for a download operation from the PC or PU after you type it in.</p>		<i>Transfer</i>	<i>MPI-Trans</i>
<i>Transfer</i>	<i>MPI-Trans</i>			
5.	<p>Start the download operation on the PC or PU. With a proper connection, downloading of the configuration commences to the OP3. If the connection is not in order or if a connection has not been made, a corresponding system message is issued.</p> <p>The settings required in ProTool for the download operation will be found in the <i>User's Guide ProTool – Configuring Text-based Displays</i>.</p>			
6.	<p>If the download operation is successful, the OP3 re-starts and goes to message level.</p>			

**Recommissioning**

In recommissioning, the configuration loaded on the OP3 is replaced with another. This can be done either by using the RS232 interface or the MPI. For the MPI, the configuration computer – that is, a PC or PU – must be equipped with an MPI card.

To recommission the OP3, proceed as follows:

	RS232	MPI		
1.	<p>Connect the RS232 interface of the OP3 to the COM1/2 serial interface of your PC or PU.</p> <p>To do this, use the serial connecting cable supplied with the OP3.</p>	<p>Interconnect the MPIs of the OP3 and the PC or PU.</p> <p>To do this, use the MPI connecting cable supplied with the OP3.</p>		
2.	<p>When connecting via the S7 bus connector, connect the power supply to the OP3. To do this, use either the 24-V power supply cable supplied with the OP3 or one of the two plug-in power supply units referred to in Section 15.2.</p>			
3.	<p>Call standard screen <i>System</i> → <i>OPMode</i> and select the mode</p> <table border="1" style="width: 100%; border-collapse: collapse;"> <tr> <td style="text-align: center;"><i>Transfer</i></td> <td style="text-align: center;"><i>MPI-Trans</i></td> </tr> </table> <p>The OP3 prompts you to enter the system administrator's password (default: 100) and waits for a download operation from the PC or PU after you type it in.</p> <p>If this standard screen is not available in your configuration, press the following three keys simultaneously while turning on the OP3's power supply</p> <div style="text-align: center;">  </div> <p>This key combination deletes the current configuration. The OP3 loads the English-language standard screens. You use them to enable Transfer mode.</p>		<i>Transfer</i>	<i>MPI-Trans</i>
<i>Transfer</i>	<i>MPI-Trans</i>			
4.	<p>Start the download operation on the PC or PU. With a proper connection, downloading of the configuration commences to the OP3. If the connection is not in order or if a connection has not been made, a corresponding system message is issued.</p> <p>The settings required in ProTool for the download operation will be found in the <i>User's Guide ProTool – Configuring Text-based Displays</i>.</p>			
5.	<p>If the download operation is successful, the OP3 re-starts and goes to message level.</p>			



# **DEVICE DESCRIPTION,                      Part IV** **TEST AND MONITORING FUNCTIONS**

**15    Device Description**

**16    Test and Monitoring Functions**



## Device Description

### In this chapter

This chapter provides information about the dimensions of the OP3, the positions of the connection elements and manual adjustment of the display contrast.

### 15.1 Dimension Drawings

#### Device and mounting dimensions

Figure 15-1 shows the dimension drawings of the OP3.

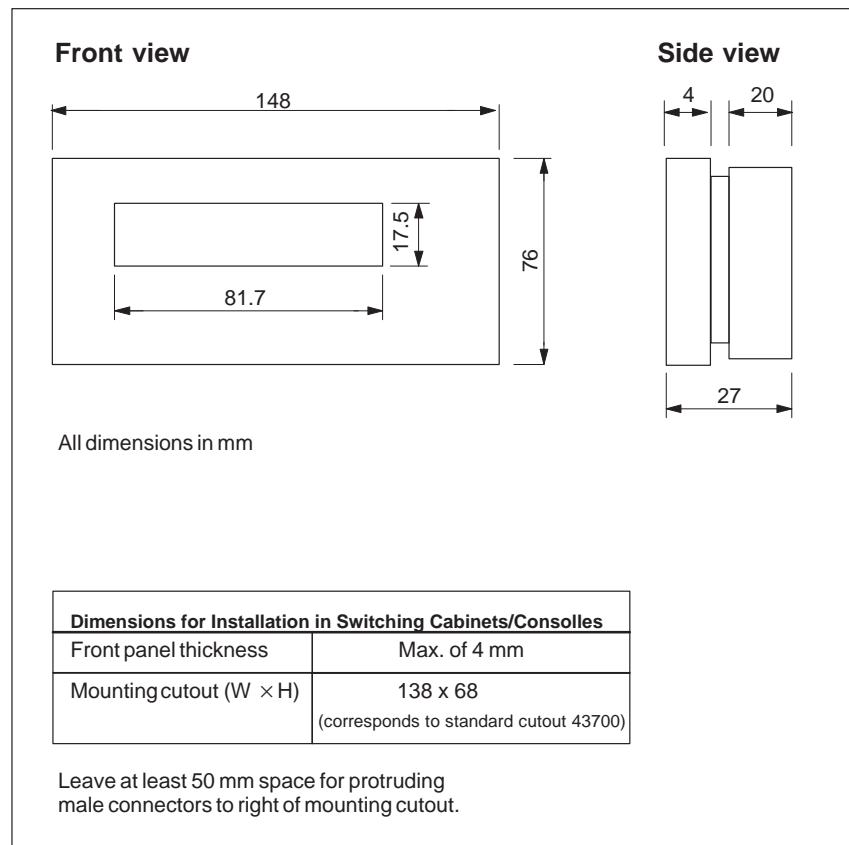

Figure 15-1 OP3 Dimensions

## 15.2 Connection Elements

### Positions of the connection elements

The connections for the

- power supply,
- RS232 interface and
- MPI interface

are located on the right side of the housing.

The connection elements and their positions are illustrated in 15-2.

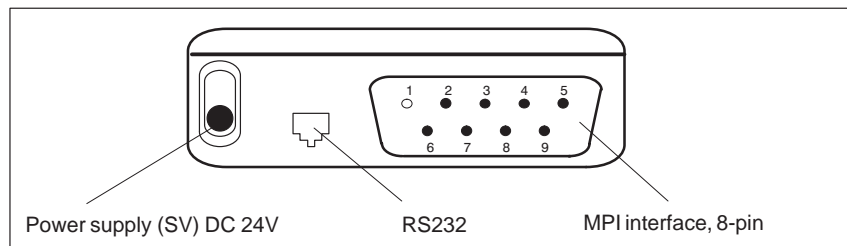

Figure 15-2 Positions of the Connection Elements on the OP3 (right hand of housing)

### Power supply

Power (24V DC) is supplied via the SV connection when the OP3 is not connected to a SIMATIC S7 PLC (serial download/offline mode).

For this purpose, use one of the following optional plug-in power supply units

- 6ES7705-0AA00-1AA0 for the 230V AC alternating voltage connection,
- 6ES7705-0AA00-1BA0 for the 120V AC alternating voltage connection.

If the OP3 is connected through the MPI interface to a SIMATIC S7 PLC, it is supplied with power by the PLC through the MPI interface.

### RS232 Interface

Pin assignment of the RS232 interface:

Pin	Meaning
1	Shield
2	GND
3	RxD
4	TxD
5	CTS
6	RTS



**Note**

If you require the hardware test (refer to Section 16) to test the RS232 interface, connect pins 3 and 4 to the 9-pin subminiature D connector of the serial transfer cable.

The OP3 is connected to the RS232 interface of the PC by means of the cable supplied. The configuration of the interconnecting cable is shown below.

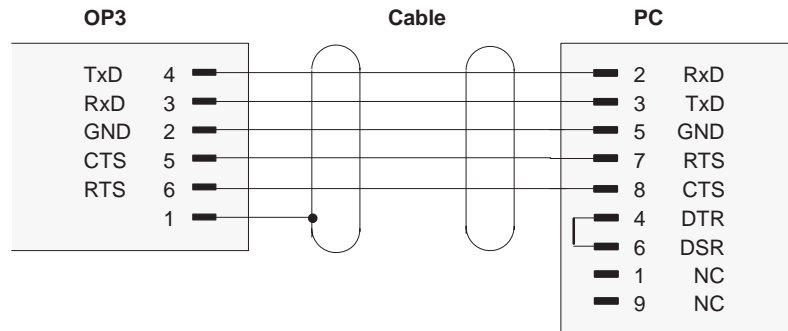
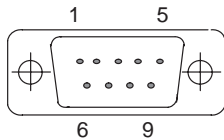

Figure 15-3 Configuration of the Interconnecting Cable

**MPI (RS485) interface**

The OP3 is connected to the SIMATIC S7 PLC through the MPI interface. The pin assignment of the MPI interface is shown in the following table.



Pin	Meaning
1	Code
2	M24V
3	RS485 line B
4	RTSAS
5	M5V
6	NC (not assigned)
7	P24V
8	RS485 line A
9	NC (not assigned)

The OP3 is connected to the MPI interface of the SIMATIC S7 PLC by means of the cable supplied. The configuration of the interconnecting cable is shown below.

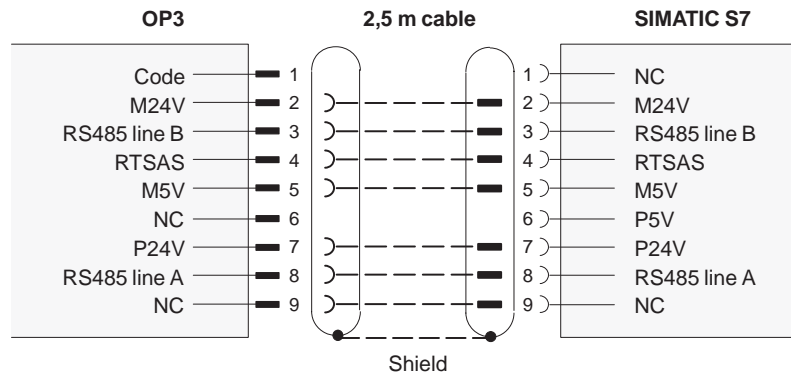



Figure 15-4 Configuration of the Interconnecting Cable

### 15.3 Contrast Control

#### Adjusting the display contrast

At the rear of the OP3, next to the symbol  there is a countersunk potentiometer screw which is turned left or right to adjust the display contrast.

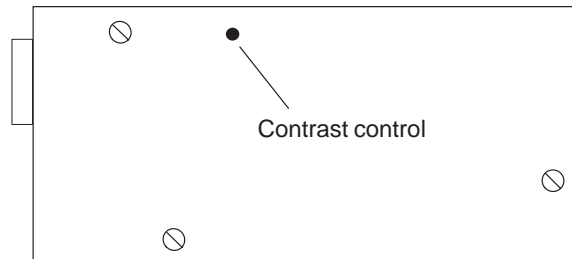

Figure 15-5 Contrast Control

## Test and Monitoring Functions

### Hardware test

Apart from a brief initial start test ("eprom test", "ram test", "flash test"), which is performed on every cold start of the OP3, a hardware test with test functions for all the important components of the device can be initiated by operator input.

Hardware test displays are in English, irrespective of the language set.

### Initiating the hardware test

The hardware test is not initiated by means of the screen level but on turning on the supply voltage. Press the following three arrow keys simultaneously



### Hardware test menu

You can choose the following tests from the hardware test menu:

- CPU TEST,
- RAM TEST,
- EPROM TEST,
- FLASH TEST,
- V.24 (RS232) TEST,
- KEYBOARD TEST,
- DISPLAY TEST and
- TEST\_ALL.

Choose the test you require with arrow keys ↓ and ↑; start the test by pressing ENTER. The >> and << symbols show the menu item you selected in the left and right borders of the display.

While an initiated test is in progress, an "active" message is displayed. If an initiated test terminates without errors, an "ok" message appears on the display for about two seconds.

You terminate a hardware test by choosing "END OF TEST" from the menu.

**CPU TEST** The internal registers, timers and the interrupt controller of the processor are tested.

**RAM TEST** The entire static RAM is "read" tested and then "write" tested, its previous contents being overwritten as a result.

**EPROM TEST** The checksums of the memories are determined.  
**FLASH TEST** In the FLASH TEST, the size and status of the FLASH memory are displayed – for example, 128 k, "empty" or "prg." for programmed).

**RS232-TEST** In the RS232 interface test, data are transferred by the sender to the recipient of the interface through a shorting plug.

---

**Note**

For this test, connect pins 3 and 4 to the 9-pin subminiature D connector of the transfer cable (refer to chapter 15).

---

**KEYBOARD TEST** When you press a key on the system keyboard, the name of the key – for example, ENTER – is displayed; the key number is displayed in the case of numeric keys.

**End of test:**

If a key is not pressed for 5 seconds, the test is aborted and you return to the menu.

**DISPLAY TEST** The following test screens are displayed in succession:

1. Display dark
2. Display light
3. Cursor runs from left to right on both lines of the display and back again.

**TEST\_ALL** All menu items of the hardware test are performed in succession. In the event of a fault, the test program remains at a standstill for about 20 seconds. It then performs the remaining tests and afterwards goes to the menu item in which the first fault occurred.

---

**Note**

For this test, connect pins 3 and 4 to the 9-pin subminiature D connector of the serial transfer cable (refer to chapter 15).

---

**END OF TEST** A hardware reset is initiated and a cold start performed.

# APPENDICES

# Part V

- A Brief Description of Standard Screens**
- B System Messages**
- C Technical Data**
- D ESD Guidelines**
- E SIMATIC HMI Documentation**



# Brief Description of Standard Screens

# A

## Overview

The table below presents an overview of all the standard screens for the OP3. Apart from a brief comment on functions, mention is made of the requisite password level. The "Level 1" column lists the screens that you can choose from the basic screen. These screens allow you to make different calls, which are listed under "Level 2".

Level 1	Level 2	Function	Password Level
<i>Screens</i>		<ul style="list-style-type: none"> <li>• Display directory for screens</li> <li>• Display screens</li> </ul>	0
<i>Screens</i> →	<i>Counter</i>	<ul style="list-style-type: none"> <li>• Display counter actual value</li> <li>• Enter counter setpoint</li> </ul>	0
<i>Screens</i> →	<i>Timer</i>	<ul style="list-style-type: none"> <li>• Display actual counter value</li> <li>• Enter the timer setpoint</li> </ul>	0
<i>System</i> →	<i>Mode</i>	Set OP3 mode: Online, Offline, Transfer, MPI Transfer	9
<i>System</i> →	<i>Languages</i>	Choose language	2
<i>System</i> →	<i>Dat/Time</i>	Adjust date and time	4
<i>System</i> →	<i>MPI-Addr</i>	Set address in the MPI network configuration	6
<i>StatVAR</i>		Display SIMATIC S7 operands	0
<i>ForceVAR</i>		Display and modify SIMATIC S7 operands	8
<i>Password</i> →	<i>Logout</i>	Log out a user and goes back to message level	0
<i>Password</i> →	<i>Edit</i>	<ul style="list-style-type: none"> <li>• Display password list</li> <li>• Assign and modify passwords and their levels</li> <li>• Delete passwords</li> </ul>	9





## System Messages

### Message number

System messages on the OP3 can be categorized in different ways.

Information on the category to which a system message belongs is contained in the message number:

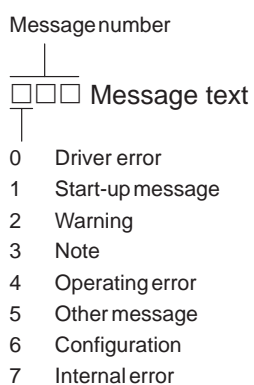

The message category gives you a rough idea of the cause of a system message.

A few important system messages are shown below together with their causes and the action that has to be taken to remedy the errors.

Self-explanatory system messages are not included.

---

### Note

Messages are displayed in English until configuration data have been transferred to the OP3.

---

**Status messages**

The table below lists the status messages.

Message	Cause	Action
Please wait	Mode in process of being changed	
Ready for transfer	Waiting for data from PU or PC	
Data transfer	Data being transferred between PU or PC and OP3	
Firmware not compatible	Firmware cannot be used for current configuration.	
EPROM memory failure	Memory submodule defective	Return device for repair
RAM memory failure		
Flash memory failure	Memory submodule defective or transmission error	Re-send configuration or return device for repair

Message	Cause	Action
\$ 005	<b>Internal Error</b>	
\$ 006	<p>Error in data transmission during MPI transfer (message with 1 variable)</p> <ul style="list-style-type: none"> <li>1 Internal error</li> <li>4 The connection to ProTool/Lite was disrupted</li> <li>5 Flash error (upon write)</li> <li>6 Flash is full (configuration too large)</li> <li>7 Flash error (upon delete)</li> <li>8 Wrong object number</li> <li>9 Wrong object length</li> <li>10 Wrong block number</li> <li>11 Wrong block length</li> <li>12 Undefined job</li> <li>13 Unexpected job</li> <li>14 Unexpected mail type</li> </ul> <p><b>Transfer Error No: Var1 Sts:Var2</b></p> <p>Error in the data transmission during the serial transfer (message with 2 variable)</p> <p><b>Variable 1</b></p> <p><b>Faulty Function</b></p> <ul style="list-style-type: none"> <li>0 Initiation of function</li> <li>1 Data reception</li> <li>2 Data transmission</li> <li>3 Message block transmission</li> <li>4 Conclusion of function</li> </ul> <p><b>Variable 2</b></p> <ul style="list-style-type: none"> <li>1 Wrong parameter</li> <li>3 Timeout error</li> <li>5 Parity error</li> <li>6 Framing error</li> <li>7 Overrun error</li> <li>8 Break on line</li> <li>9 Receive buffer overflow</li> <li>10 Control character error on reception</li> <li>11 Protocolling error</li> </ul>	<p>Check connection and re-send</p> <p>Internal error HW error, internal error or Transfer error: Re-send Re-send Re-send Re-send Re-send Insert cable Re-send Re-send Re-send</p>

Message	Cause	Action
\$ 040	No response from PLC Cable defective or not plugged in	Check physical connection
\$ 041	Temporary driver error	Restart PC Re-send configuration
\$ 044	MPI transfer error	
\$ 045	No connection to PLC No. x (message with variable )	
\$ 100	Invalid RAM contents	
\$ 104	Download mode aborted by operator input (OP3 or ProTool/Lite)	
\$ 119	Automatic start by OP3 Password list is not necessarily deleted	
\$ 202	Error on reading date	Re-enter date (return OP3 for repair)
\$ 203	Error on reading time	Re-enter time (return OP3 for repair)
\$ 311	Flag x does not exist on PLC	Modify configuration (variable)
\$ 316 \$ 317	Current password level too low for required operator input	Login at higher password level
\$ 318	Login attempted with invalid password	
\$ 319	While editing the password, a password was entered which already exists	
\$ 320 \$ 321	Superuser level cannot be modified; password invalid	Enter password before defining level
\$ 322	Password too short	Password must have at least 3 characters
\$ 324	The screen number you entered does not exist	
\$ 340	When the status function is being executed on the PU, you cannot operate the OP3	
\$ 401	Entered value does not match display format	
\$ 402	Operating error on STATUS VAR or FORCE VAR screen	
\$ 403	Incorrect time input	

Message	Cause	Action
\$ 404	Incorrect date input	
\$ 409	Lower limit for input ignored	Enter value greater than or equal to <i>Var</i>
\$ 410	Upper limit for input ignored	Enter value smaller than or equal to <i>Var</i>
\$ 500 \$ 501 \$ 502 \$ 503	<ul style="list-style-type: none"> <li>– Transfer to PLC not possible at present</li> <li>– PLC overloaded</li> </ul>	
\$ 520	Too many cross-jumps stored	Go to message level
\$ 522	Screen cannot be chosen as there is insufficient memory. Results in restart with memory optimization	<ol style="list-style-type: none"> <li>1. Delete unused fields from configuration</li> <li>2. Configure smaller screen (with fewer fields) or partition screen</li> </ol>
\$ 541	Peripheral x does not exist	
\$ 542	Input x does not exist	
\$ 543	Output x does not exist	
\$ 544	Flag x does not exist	
\$ 545 \$ 546	DB No. x does not exist	
\$ 549	Counter x does not exist	
\$ 550	Timer x does not exist	
\$ 600	Wrong parameter transferred in Download mode (overflow warning)	Set required value by means of standard screen or the PLC
\$ 601	Wrong parameter transferred in Download mode	Set required value by means of standard screen or the PLC
\$ 604	Message not configured for a set message bit	Configure and transfer messages
\$ 606 \$ 607 \$ 609 \$ 610 \$ 611	Incorrect configuration	See internal errors
\$ 613	Data block does not exist or is too short	Create DB of requisite length on PLC
\$ 616 \$ 617	Incorrect configuration	See Internal Errors
\$ 619	Error in Download mode (data structure for setpoint presetting)	Restart Download mode, Repeat transfer of configuration

Message	Cause	Action
\$ 620	Wrong parameter transferred in Download mode	Repeat transfer of configuration
\$ 621	Wrong parameter transferred in Download mode (message type)	Set required value by means of standard screen or the PLC
\$ 623		See Internal Errors
\$ 627	Incorrect configuration	See Internal Errors
\$ 631	(Message with one variable) 5, 6 Initiated event message not configured 25 Invalid field type 60 Event message area has 0 polling time 8...20 Internal errors	Add to configuration and repeat transfer
\$ 632	(Message with variable) 12 Screen contains no entries 3, 6, 7, 8, 11, 13 Internal errors	Add to configuration and repeat transfer
\$ 634	(Message with variable) 18 Screen title not configured 0 ... 8, 34 Internal errors	Add to configuration and repeat transfer

Message	Cause	Action
\$ 635	(Message with variable) 6 Message or entry text not configured for current language 18 Screen title not configured 25 Invalid data format for symbolic field 33 Invalid data format for setpoint 48 Too many fields on process screen 50 Variable does not exist for soft keys 55 Soft key specified in entry does not exist 60 Loadable symbol set is larger than 8 characters 61 Configured field length too small 63 Invalid display format configured 64 Invalid data type configured 7...9, 19, 28, 41...43 Internal errors	Add to or modify configuration and repeat transfer
\$ 636 \$ 637	Initiated event message (No. x) not configured	Add to configuration and repeat transfer
\$ 645 \$ 649	Internal errors	
\$ 650	Area pointer for function you used not configured	Configure area pointer
\$ 651	Internal error	
\$ 668	MPI configuration error	
\$ 702	<b>Internal error</b> (actual value error)	
\$ 703	<b>Internal error</b> (job faulty)	
\$ 704	Flash memory full	Restrict configuration
\$ 706	<b>Internal error</b> (unknown message acknowledged)	
\$ 7xx	<b>Internal errors</b>	

**Internal errors**

Proceed as follows for all system messages that refer to "internal errors":

- a) Switch off the OP3, put the PLC in STOP mode and restart the OP and the PLC.
- b) Put the OP3 during startup in Download mode, transfer the configuration again and restart the OP3 and the PLC.
- c) If the error continues to occur, please contact the nearest Siemens branch office. Report the number of the error that has occurred and any variable that may be included in the message.



# Technical Data

# C

<b>Housing</b>	
Front panel B × H × D (mm)	148 × 76 × 27
Mounting cutout B × H (mm)	138 × 68 (DIN 43700)
Useful depth approx. (mm)	25
Protection type	
front	IP65
rear	IP20
Weight approx. (kg)	0,22

<b>Processor</b>	
Type	80C32 (Intel)
Clock frequency	10.5 MHz

<b>Memory</b>	
Flash memory for configuration data	128 KB
SRAM working memory	128 KB
EPROM firmware	512 KB

<b>Display</b>	
Type	STN display with LED background illumination
Number of lines	2
Characters per line	20
Character height (mm)	5

<b>Keyboard</b>	
Type	Membrane keyboard
Number of system keys	18

<b>Supply voltage</b>	
Rated voltage	+24 VDC
Permissible range	+15 ... +32 VDC
Maximum permissible transients	35 V (500 ms)
Time between two transients	Min. of 50 sec.
Current consumption Average Max. continuous current Max. switch-on current	70 mA 110 mA at 24 V 3 A, 10 µs (bei 30 V)
Fuse	No fuse in the OP! Supply voltage must be limited by fuse/current limiter to $I_N \leq 3 \text{ A}$ !

<b>Ambient conditions</b>	
Operating temperature	0 °C to 60 °C
Storage/transport	-20 °C to +60 °C
Relative humidity Operation Storage/transport	5% to 85% (no condensation) 5% to 93% (no condensation)
Shock load Operation Transport	15 g/11 msec 25 g/6 msec
Vibration	1 g (up to 500 Hz)

<b>Interfaces</b>	
1 x MPI/PPI (RS 485)	For SIMATIC S7/configuration computer
1 x V.24 (RS 232)	For configuration computer

<b>Interference Immunity</b>	
Static discharge	IEC 801-2 class 3
RF irradiation	ENV 50140 class 3
Pulse modulation	ENV 50204 900 MHz $\pm$ 5 MHz
RF conduction	ENV 50141 class 3
Burst interference	IEC 801-4 class 3

<b>Interference Emission</b>	
Radio suppression class to VDE 0878, EN 55022	Class B

# ESD Guidelines

# D

## In this chapter

This chapter describes the most important precautions which must be taken to avoid damage to the electrostatically sensitive devices in the OP3.

## D.1 What Does ESD Mean?

### Electrostatically sensitive devices

Nearly all modern modules incorporate highly integrated MOS devices and components. For technological reasons, these electronic components are very sensitive to overvoltages and consequently therefore to electrostatic discharge:

The abbreviation for these

Electrostatically Sensitive Developments is "ESD"

The German abbreviation for such devices is:

"EGB" (Elektrostatisch Gefährdete Baulemente/Baugruppen)

The following symbol on plates on cabinets, mounting racks or packaging draws attention to the use of electrostatically sensitive devices and thus to the contact sensitivity of the modules concerned:

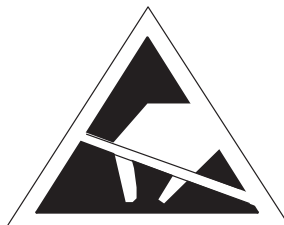

ESDs may be destroyed by voltages and energies well below the perception threshold of persons. Voltages of this kind occur as soon as a device or assembly is touched by a person who is not electrostatically discharged. Devices exposed to such overvoltages cannot immediately be detected as defective in the majority of cases, since faulty behavior may occur only after a long period of operation.

## D.2 Important Precautions against Charge

### Keep away from plastics

- Most plastics are capable of carrying high charges and it is therefore imperative that they not be placed near sensitive components.

### Grounding

- When handling electrostatically sensitive devices, make sure people, workplaces and packaging are properly grounded.

## D.3 Handling ESDs

### Rules for touching and environments

- A general rule is that modules should be touched only when this cannot be avoided owing to the work that has to be performed on them. If you have to touch them, under no circumstances should you handle printed circuit boards by touching device pins or conductor runs.
- Devices may be touched only if
  - you are grounded by permanently wearing an ESD wrist strap or
  - you are wearing ESD shoes or ESD grounding protection strips in conjunction with an ESD floor.
- Before you touch an electronic module, your body must be discharged. The simplest way of doing this is to touch a conductive, grounded object immediately beforehand – for example, bare metal parts of a control cabinet, water pipe etc.
- Modules should not be brought into contact with charge-susceptible and highly insulating materials, such as plastic films, insulating table tops and items of clothing containing synthetic fibers.
- Modules should be deposited only on conductive surfaces (tables with a ESD coating, conductive ESD cellular material, ESD bags, ESD shipping containers).
- Do not place modules near visual display units, monitors or television sets (minimum distance to screen > 10 cm).

## D.4 Measuring and Modifying ESDs

### Grounding measuring instruments/ soldering irons

- Measurements should be made on modules only when
  - the measuring instrument is grounded by means of a protective conductor or
  - the measuring head has been briefly discharged before measurements are made with a voltages measuring instrument – for example, by touching a bare metal control cabinet.
- When soldering, you must use only a grounded soldering iron.

## D.5 Shipping ESDs

### **Conductive packing**

As a matter of policy, modules and components should be stored and shipped only in conductive packing – for example, metalized plastic boxes, tin cans.

Should packing not be conductive, modules must be conductively wrapped before they are packed. You can use, for example, conductive foam rubber, ESD bags, domestic aluminum foil and paper (under no circumstances should you use plastic bags or foils).

### **Protecting/covering battery connections**

With modules containing fitted batteries, make sure that the conductive packing does not come into contact with or short-circuit battery connections; if necessary, cover battery connections beforehand with insulating tape or insulating material.



# SIMATIC HMI Documentation



## Target groups

This manual is part of the SIMATIC HMI documentation. The documentation is aimed at the following target groups:

- Newcomers
- Users
- Configurers
- Programmers
- Commissioning engineers

## How the documentation is organized

The SIMATIC HMI documentation consists of the following components:

- User's Guides for:
  - Configuration software
  - Runtime software
  - Communication between PLCs and operating units
- Equipment Manuals for the following operating units:
  - SIMATIC PC
  - MP (Multi Panel)
  - OP (Operator Panel)
  - TP (Touch Panel)
  - TD (Text Display)
  - PP (Push Button Panel)
- Online Help on the configuration software
- Start-up Guides
- First Steps

## Overview of complete documentation

The following table provides an overview of the SIMATIC HMI documentation and shows you when you require the different documents.

Documentation	Target Group	Content
First Steps with ProTool Product Brief	Newcomers	<p>This documentation guides you step by step through the configuration of</p> <ul style="list-style-type: none"> <li>• a screen with various objects</li> <li>• changing from one screen to another</li> <li>• a message.</li> </ul> <p>This documentation is available for:</p> <ul style="list-style-type: none"> <li>• OP 3, OP 5, OP 7, OP 15, OP 17</li> <li>• OP 25, OP 27, OP 35, OP 37, TP 27, TP 37</li> <li>• Windows-based systems</li> </ul>
ProTool Configuring Windows-based Systems User's Guide	Configurers	<p>Provides information on working with the ProTool/Pro configuration software. It contains</p> <ul style="list-style-type: none"> <li>• information on installation</li> <li>• basic principles of configuration</li> <li>• a detailed description of configurable objects and functions.</li> </ul> <p>This documentation is valid for Windows-based systems.</p>
ProTool Configuring Graphics Displays User's Guide	Configurers	<p>Provides information on working with the ProTool configuration software. It contains</p> <ul style="list-style-type: none"> <li>• information on installation</li> <li>• basic principles of configuration</li> <li>• a detailed description of configurable objects and functions.</li> </ul> <p>This documentation is valid for graphic display operating units.</p>
ProTool Configuring Text-based Displays User's Guide	Configurers	<p>Provides information on working with the ProTool/Lite configuration software. It contains</p> <ul style="list-style-type: none"> <li>• information on installation</li> <li>• basic principles of configuration</li> <li>• a detailed description of configurable objects and functions.</li> </ul> <p>This documentation is valid for text-based display operating units.</p>
ProTool Online Help	Configurers	<p>Provides information on the configuration computer while working with ProTool. Online Help contains</p> <ul style="list-style-type: none"> <li>• context-sensitive help</li> <li>• detailed instructions and examples</li> <li>• detailed information</li> <li>• all the information from the user guide.</li> </ul>
ProTool/Pro Runtime User's Guide	Commissioning engineers, Users	<p>Provides information on working with ProTool/Pro Runtime software. It contains</p> <ul style="list-style-type: none"> <li>• installation of the ProTool/Pro Runtime visualization software</li> <li>• commissioning and running the software on Windows-based systems.</li> </ul>
Copy Protection Start-up Guide	Commissioning engineers, Users	<p>The ProTool/Pro Runtime visualization software is a copyright product. This manual contains information on the installation, repair and uninstallation of authorizations.</p>



Documentation	Target Group	Content
Application Example Start-up Guide	Newcomers	ProTool is supplied with example configurations and the corresponding PLC programs. This documentation describes how you <ul style="list-style-type: none"> <li>• load the examples onto the operating unit and PLC</li> <li>• run the examples and</li> <li>• upgrade the connection to the PLC to suit your own specific application.</li> </ul>
SIMATIC Panel PC 670 Equipment Manual	Commissioning engineers, Users	Describes the computer unit and operating unit of the SIMATIC Panel PC 670.
MP 270 Equipment Manual TP 170A Equipment Manual	Commissioning engineers, Users	Describes the hardware and the general operation of Windows-based Panels: <ul style="list-style-type: none"> <li>• installation and commissioning instructions</li> <li>• a description of the equipment</li> <li>• operating instructions</li> <li>• instructions for connecting the PLC, printer and programming computer,</li> <li>• maintenance instructions.</li> </ul>
OP 37/Pro Equipment Manual	Commissioning engineers, Users	Describes the hardware, installation and inclusion of upgrades and options for the OP 37/Pro.
TP 27, TP 37 Equipment Manual OP 27, OP 37 Equipment Manual OP 25, OP 35, OP 45 Equipment Manual OP 7, OP 17 Equipment Manual OP 5, OP 15 Equipment Manual TD 17 Equipment Manual	Commissioning engineers, Users	Describes the hardware and general operation. It contains <ul style="list-style-type: none"> <li>• installation and commissioning instructions</li> <li>• a description of the equipment</li> <li>• instructions for connecting the PLC, printer and programming computer,</li> <li>• operating modes</li> <li>• operating instructions</li> <li>• description of the standard screens supplied with the operating unit and how to use them</li> <li>• fitting options</li> <li>• maintenance and fitting of spare parts.</li> </ul>
OP 3 Equipment Manual	Commissioning engineers, Users, Programmers	Describes the hardware of the OP3, its general operation and the connection to the SIMATIC S7.
PP 7, PP 17 Equipment Manual	Commissioning engineers, Users	Describes the hardware, installation and commissioning of push-button panels PP 7 and PP 17.

Documentation	Target Group	Content
Communication User's Guide	Programmers	<p>Provides information on connecting text-based and graphics displays to the following PLCs:</p> <ul style="list-style-type: none"> <li>• SIMATIC S5</li> <li>• SIMATIC S7</li> <li>• SIMATIC 500/505</li> <li>• drivers for other PLCs</li> </ul> <p>This documentation describes the</p> <ul style="list-style-type: none"> <li>• configuration and parameters required for connecting the devices to the PLC and the network</li> <li>• user data areas used for exchanging data between operating unit and PLC.</li> </ul>
Communication for Windows-based Systems User's Guide	Programmers	<p>Provides information on connecting Windows-based systems to the following PLCs:</p> <ul style="list-style-type: none"> <li>• SIMATIC S5</li> <li>• SIMATIC S7</li> <li>• SIMATIC 505</li> <li>• OPC</li> <li>• Allen Bradley PLC-5/SLC 500</li> <li>• Mitsubishi FX</li> <li>• Telemecanique TSX</li> </ul> <p>This documentation describes the</p> <ul style="list-style-type: none"> <li>• configuration and parameters required for connecting the devices to the PLC and the network</li> <li>• user data areas used for exchanging data between operating unit and PLC.</li> </ul>
Other PLCs Online Help	Programmers	<p>Provides information on connecting devices to PLCs, such as:</p> <ul style="list-style-type: none"> <li>• OPC</li> <li>• Mitsubishi</li> <li>• Allen Bradley</li> <li>• Telemecanique</li> <li>• Modicon</li> <li>• Omron</li> <li>• SIMATIC WinAC</li> </ul> <p>When the drives are installed, the relevant Online Help is installed at the same time.</p>
ProAgent for OP User's Guide	Configurers	<p>Provides the following information about the ProAgent optional package (process diagnosis) for OPs</p> <ul style="list-style-type: none"> <li>• configuring system-specific process diagnosis</li> <li>• detecting, locating the cause of and eliminating process errors,</li> <li>• customizing standard diagnostic screens supplied with the software.</li> </ul>

# Glossary

## A

**Area pointer** Required for enabling data transfer between the OP3 and the PLC. It contains details of the location and size of data areas in the PLC.

**Arrival of a message** The time at which a message is initiated by the PLC or OP3.

## C

**Configuration** Definition of system-specific basic settings, messages and screens using ProTool/Lite configuration software.

## D

**Departure of a message** The time at which a message is withdrawn by the PLC.

**Display function** Function resulting in a change of display contents – for example, "Display Message Level" or "Display Screen".

**Download mode** OP3 mode in which data are transferred from the programming unit to the OP3, or vice versa.

**Duration of display** Time between the arrival of an event message and its departure.

## E

**Event message** Draws attention to specific operating states in the machine or system connected to the PLC.

## F

<b>Fields</b>	Reserved areas in configured or permanent texts, used to output and/or input certain values.
<b>Flash memory</b>	Programmable memory which can be deleted quickly and then re-written.
<b>Function</b>	Prompts the OP3 to work by choosing it – for example, Delete Buffer.
<b>Function screen</b>	A screen stored in the firmware. It cannot be modified in the configuration. Function screens implement functions configured at the works for making settings on the OP3.

## M

<b>Message level</b>	Control level of the OP3 at which initiated messages are displayed.
----------------------	---

## N

<b>Normal mode</b>	Mode of the OP3 in which messages are displayed and screens can be manipulated.
--------------------	---

## O

<b>Output field</b>	Field for displaying an actual value.
---------------------	---------------------------------------

## P

<b>Password Password level</b>	To service a protected function, a password has to be entered which exhibits a certain password level. The password level defines the permissions of an operator. The requisite password level is preset by means of configuration and can range from 0 (the lowest level) to 9 (the highest level).
------------------------------------	--

## S

<b>Screen</b>	Form of presenting logically associated process data which can be displayed collectively on the OP3 and modified individually.
<b>Screen entry</b>	Element of a screen; consists of an entry number, texts and variables.
<b>Screen level</b>	Editing level of the OP3 at which screens can be monitored and manipulated
<b>Selection field</b>	Field for for setting values of parameters (one of several defined values can be chosen).
<b>Soft keys</b>	Keys that can be assigned with variable functions (depending on displayed screen entry)
<b>Startup test</b>	Check on the status of the central processing unit and memories each time the supply voltage is applied.
<b>System message</b>	Draws attention to internal conditions on the OP3 and the PLC.



# Index

## A

- Access permissions, 6-1
- Access protection, 6-1
- Actual value, 5-2
- Actual-value display, 2-1
- Address
  - OP3, 12-2
  - S7, 12-2
- Address area, event messages, 7-2
- Address modification in MPI network configuration, 10-3
- Adjust
  - date, A-1
  - time, A-1
- Allocate, passwords, 6-3
- Alphanumeric values, input, 3-4, 3-6
- Ambient conditions, C-2
- Area pointer, 11-4, 11-6, Glossary-1
- Arrival, message, Glossary-1
- Arrived messages, 7-2
- Arrow keys, 3-2
- Assignment digits / soft keys, 3-3
- Assignment of system keyboard, 11-6

## B

- Basic screen, 4-3
- Baud rate, 12-2, 12-4
- Bit, setting, 11-1, 11-6
- Bit pattern format, 3-5
- Branch
  - in standard screens, 4-5
  - with soft keys, 11-1
- Branch back, 3-2, 4-2
- Burst interference, C-2
- Bus connector, 13-5

## C

- Calling, function, 4-5
- Character height, 1-3, C-1
- Choice, of screens, 5-3

## Choose

- language, A-1
- screens, 4-5
- Clock frequency, C-1
- Cold start, 16-1
- COM1/2, 14-2, 14-3
- Combined I/O, 5-2
- Commissioning, 14-1
- Communication, 2-1, 12-1
- Configuration, 1-3, Glossary-1
  - download, 14-2, 14-3
- Configuration computer connection, 13-4
- Configuration Phase, 1-2
- Connecting cable, 14-2, 14-3
- Connection configuration diagram, 13-4, 13-5
- Connection elements, 15-2
- Connection ID, 12-6
- Connection OP3/S7, 2-2
- Connection to PLC, 13-5
- Connection types, 12-1
- Contrast, adjusting, 2-1, 13-2, 15-4
- Control and response bits, 12-6
- Counter, 2-1, 8-1, A-1
- Counter setpoint, 8-1
- Counter status, 8-1
- CPU TEST, 16-2
- Cross-jump destination, 3-2, 11-2

## D

- Data, technical, C-1
- Data formats, 9-2
- Data transmission rate, 12-2
- Data types, 9-2
- Date
  - adjust, A-1
  - and time, 12-6, 12-7
  - setting, 10-2
- Date in messages, 7-1
- Decimal places, 3-5
- Degree of protection, 13-1
- Delete, password, 6-3, A-1
- Departed message, 7-2, Glossary-1

- Depth, C-1
- Device description, 15-1
- Device type, 7-3
- Diagnostic function, 2-1
- Digits / soft keys, assign, 3-3
- Dimension drawings, 15-1
- Directory, screens, 4-3
- Discharge, static , C-2
- Display, 1-3, 2-1, C-1
  - contrast, 15-4
  - messages, 7-4
  - operand values, 9-1
  - password list, 6-2
  - Test, 16-2
- Display function, Glossary-1
- Display priority, 7-3, 7-4
- Documentation, E-1
- Download
  - MPI, 10-2
  - serial, 10-2
- Download mode, Glossary-1
- Downloading, data, 10-2
- Dual assignment, keys, 3-2
- Duration of display, Glossary-1

## E

- Edit
  - password, A-1
  - screens, 5-3
- Electrical installation, 13-3
- Electrostatic discharge, D-1
- EMC-compatible design, 13-3
- END OF TEST, 16-2
- ENTER, 3-2, 4-2
- Entering a point, 3-2
- Entering symbolic values, 3-4
- Entries in screens, 5-1
- Entry number, 11-4
- Entry text, 5-2
- EPROM
  - firmware, C-1
  - test, 16-2
- Error, internal, B-8
- ESC key, 3-2
- ESCAPE, 3-2, 4-2
- ESD, D-1
- ESD guidelines, D-1
- Evaluate, screen number, 11-4
- Event message area, 7-2
- Event messages, 2-1, 7-1, Glossary-1
  - scrolling through, 7-5

## F

- Field entries, undo, 3-2
- Fields, 5-2, Glossary-2
  - I/O fields, 5-2
    - actual value, 5-2
    - date, 5-2
    - setpoint, 5-2
    - time, 5-2
- Firmware, 4-1, 7-3
- FLASH, test, 16-2
- Flash, memory, C-1, Glossary-2
- Flashing in messages, 7-1
- Font, alphanumeric, 3-6
- FORCE VAR, 4-3, 9-1, A-1
- Format field, 9-1
- Front panel, C-1
- Front panel cutout, 13-1
- Front view, 15-1
- Frontpanel thickness, 15-1
- Function, calling, 4-5
- Function screen, Glossary-2
- Functionality, 2-1
- Functions, Glossary-2

## G

- Gasket, 13-1, 13-2
- General operation, 3-1
- Glossary, Glossary-1

## H

- Handling ESD Assemblies, D-2
- Hardware
  - clock, 10-2
  - EMC-compatible design, 13-3
  - reset, 16-2
  - test, 16-1
- Hide, system message, 3-2
- Hierarchy
  - in self-defined screens, 11-2
  - password levels, 6-1
  - standard screens, 4-3, 4-5
- Housing, C-1
- HSA, 12-4

## I

- I/O fields, 5-2
- ID for special screen, 11-4



Incorrect input, canceling, 3-4  
 Inhibiting, system messages, 7-3  
 Initial commissioning, 14-2  
 Initial startup, 14-1  
 Input  
   alphanumeric values, 3-6  
   left-justified, 3-5  
   letters, 3-6  
   numerical values, 3-5  
   terminating, 3-2  
   values, 3-4  
 Input fields, 3-4, 5-2  
 Input of numerical values, 3-4  
 Installation, 13-1, 13-2  
 Installation instructions, 13-3  
 Interconnecting cable, 15-3  
 Interface, 1-3, 12-2, 12-4  
   MPI, 14-2, 14-3  
   RS232, 14-2, 14-3  
 Interface area, 12-1  
   SIMATIC S7 connection, 12-5  
 Interference emission, C-2  
 Interference immunity, C-2  
 Interference-proof design, 13-3  
 Internal errors, B-7, B-8  
 Irradiation, C-2

**K**

Keyboard, 1-3, 3-1  
   assignment, 11-6  
   group bit, 11-6  
   test, 16-2  
   type, C-1  
 Keypad, 1-3, 3-1  
 Keys  
   arrow keys, 3-2  
   combination for hardware test, 16-1  
   decimal point, 3-2  
   ENTER key, 3-2  
   ESCAPE, 3-2  
   numeric, 3-1  
   second function, 3-2  
   SHIFT, 3-2  
   sign key, 3-2  
   soft, 3-1

**L**

Languages, 2-1  
   select, 10-1, A-1  
 LCD display, 1-3  
 Left-justified input, 3-5  
 Letter input, 3-6  
 Limit value check, 2-1, 3-5  
 Literature, E-1  
 Login, 6-2  
 Login on OP3, 6-2  
 Logout, 4-3, 6-2, A-1  
 Logout on OP3, 6-2

**M**

Measurements, on ESD assemblies, D-2  
 Mechanical installation, 13-2  
 Memory, C-1  
 Message area, 7-5  
 Message bit procedure, 7-2  
 Message buffer, 7-4  
 Message level, 4-1, Glossary-2  
 Message number, 7-2  
 Message shower, 7-4  
 Messages, 7-1  
   arrived, 7-2  
   category, B-1  
   departed, 7-2  
   displaying, 7-4  
   number, B-1  
   priorities, 7-4  
   updating, 7-2  
 Minus key, 3-2  
 Mode, 10-2, A-1  
 Mode setting, 10-2  
 Modify  
   address in MPI network configuration, 10-3  
   operand values, 9-1  
   password, 6-3, A-1  
   password level, 6-3  
   screens, 5-3  
 Monitoring functions, 16-1  
 Mounting, 13-2  
   cutout, 13-1  
 Mounting cutout, 15-1, C-1

Mounting dimensions, 15-1

MPI, 2-1

address, 9-1, 12-4

card, 14-2

connecting cable, 14-2, 14-3

connection, 1-3

connection via, 14-2

interface, 14-2, 14-3, 15-3

network configuration, modifying address,  
10-3

set address, A-1

transfer, 14-2, 14-3

MPI download, 10-2

Multi-Point Interface, 12-1

## N

Network configuration

SIMATIC S7-200, 12-2

SIMATIC S7-300, 12-3

Normal mode, Glossary-2

Normal operation, 14-1

Notices to operators in messages, 7-1

Numeric keys, 3-1

## O

Offline mode, 10-2

Online mode, 10-2

OP address, 12-2

OP restart, 12-6

Operand field, 9-1

Operand value display, 9-1

Operating level, changing, 4-2

Operating levels, 4-1, 4-2

Operating temperature, C-2

Operation, A-1

general, 3-1

Operator guidance, process-dependent, 11-1

Order

arrived messages, 7-4

displayed messages, 7-4

Output field, 5-2, Glossary-2

Overheating, prevention, 13-1

Overvoltage, D-1

## P

Packing, D-3

Password, A-1, Glossary-2

allocating, 6-3

construction, 6-3

deleting, 6-3

format, 6-3

index, 6-2

level, 2-1, 6-1, 6-2, 6-3, A-1, Glossary-2

list, 6-2

management, 6-2

modify, 6-3, A-1

processing, 4-3

protection, 2-1, 6-1

Performance, 5-2

PU functions, A-1

Pin assignment of the MPI interface, 15-3

PLC operands, 9-1

PLC values, updating, 5-2

Plug-in power supply unit, 15-2

Plus key, 3-2

Point input, 3-5

Point-to-Point Interface, 12-1

Polling time, 5-2, 7-2, 11-6

Power supply, 13-3, 15-2

Power supply cable, 14-2, 14-3

PPI, 2-1

PPI address, 12-2

Process control phase, 1-1, 1-2

Process value display, 5-1

Process-dependent operator guidance, 11-1

Processor type, C-1

Product description, 1-1

Profile, 12-4

Protection against static charges, D-2

Protection type, C-1

PU functions, 4-3, 9-1

Pulse modulation, C-2

## R

Rack, 12-4

Radio suppression class, C-2

RAM TEST, 16-2

Rated voltage, C-2

Reading the S7 system time, 12-8

Recommissioning, 14-3

Repetitive function, 3-3

Reset when scrolling, 3-2

Restart, 12-6, 14-1

RF conduction, C-2

RF irradiation, C-2

- RS232
  - connection, 1-3
  - interface, 14-2, 14-3
  - Test, 16-2
  
- S**
- S7 configuration, 12-3
- S7 data formats, 9-2
- S7 data types, 9-2
- S7 system time
  - reading, 12-8
  - setting, 12-9
- S7-200, maximum number of OP3s, 12-2
- S7-300, number of nodes, 12-3
- Screen directory, 4-3, 5-1, 5-3, A-1
- Screen entries, 5-2, Glossary-3
- Screen hierarchy, 4-1, 4-3, 4-5, 11-2
- Screen level, 4-1, Glossary-3
- Screen number, 5-1
  - evaluating, 11-4
- Screen number area, 11-4
- Screens, 2-1, 4-3, 5-1, Glossary-3
  - choice, 5-3
  - choosing, 4-5
  - components, 5-1
  - display, A-1
  - editing, 5-3
  - entries, 2-1, 5-1
  - fields, 2-1
  - linking, 4-1
  - maximum number, 2-1
  - setpoint input, 2-1
  - title, 5-1
- Scroll screen function, 4-5
- Scrolling through event messages, 7-5
- Second function, keys, 3-2
- Side view, 15-1
- Select, language, 10-1
- Selection field, Glossary-3
- Self-test, 14-2
- Serial download, 10-2
- Serious system messages, 7-3
- Set
  - date, 10-2
  - mode, 10-2
  - MPI address, A-1
  - time, 10-2
- Setpoint, 5-2
- Setting, OP3 mode, A-1
- Setting the S7 system time, 12-9
- SHIFT, 3-1, 3-2
- SHIFT key, 3-2
- Shipping, ESD assemblies, D-3
- Shorting plug, 16-2
- Sign key, 3-2
- Signal lines, 13-3
- SIMATIC HMI documentation, E-1
- SIMATIC S7 connection
  - interface area, 12-5
    - S7-200 via PPI, 12-2
    - S7-300 via MPI, 12-3
- SIMATIC S7-200, 12-2
- SIMATIC S7-300, 12-3
- Slot, 12-4
- Soft keys, 1-3, 3-1, 4-5, 5-2, 5-3, Glossary-3
  - branching, 11-1
- Soft keys / digits, assign, 3-3
- Software clock, 10-2
- Soldering, ESD assemblies, D-2
- Special screen, 11-5
- SRAM working memory, C-1
- Standard configurations, 4-3
- Standard functions, 4-1
- Standard screens, 4-1, 4-3, A-1
- Standby message, 4-1, 7-3
- Start, test, 16-1
- Start screen, 4-1, 11-2
- Start-up, test, Glossary-3
- Static discharge, C-2
- Station address, 12-4
- STATUS VAR, 4-3, 9-1, A-1
- Storage conditions, C-2
- Structure of the documentation, E-1
- Superuser, 4-3, 6-1
  - password, 14-2, 14-3
- Supply voltage, C-2
- Symbolic value input, 3-6
- Synchronization of OP3 & S7, 12-1
- System administrator, password, 6-1
- System keyboard, 1-3, 3-1
  - assignment, 11-6
- System keys, C-1
- System messages, 7-3, B-1, Glossary-3
  - hiding, 3-2
  - inhibiting, 7-3
  - terminating, 4-2
- System settings, 4-3, 10-1, A-1
  
- T**
- Target groups, E-1
- Technical data, C-1
- Terminate, system message, 4-2

Test functions, 16-1  
TEST\_ALL, 16-2  
Text instead of a value, 3-6  
Time  
    adjust, A-1  
    and date, 12-6, 12-7  
    in messages, 7-1  
    setting, 10-2  
Time base, 8-2  
Timer, 2-1, A-1  
Timer actual value, 8-2  
Timer setpoint, 8-2  
Timers, 8-1, 8-2  
Title of screens, 5-1  
Transfer mode, 14-2, 14-3  
Transients, permissible, C-2  
Transport conditions, C-2

## U

Unauthorized operation, 4-5  
Undo, 3-2

Updating  
    messages, 7-2  
    PLC operands, 9-2  
    screen entries, 5-2  
User data areas, 12-1

## V

V.24, Test, 16-2  
Value field, 9-1  
Values, entering numerical, 3-5  
Values, input, 3-4  
    alphanumeric, 3-4  
    numerical, 3-4  
    symbolic, 3-4, 3-6  
Variable memory, 12-5  
Variables, 2-1  
Ventilation slits, 13-1

## W

Weight, C-1